

LVDT Distance-Addons

User Manual

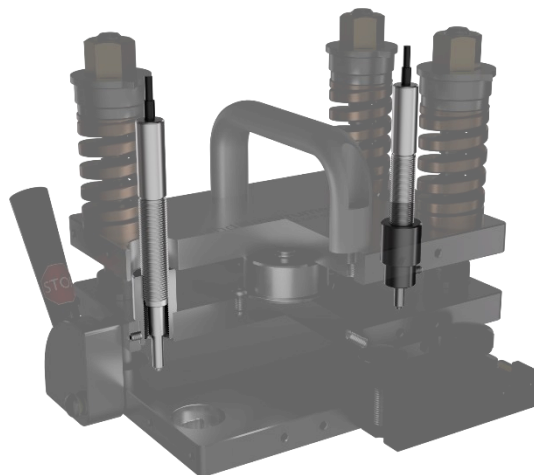
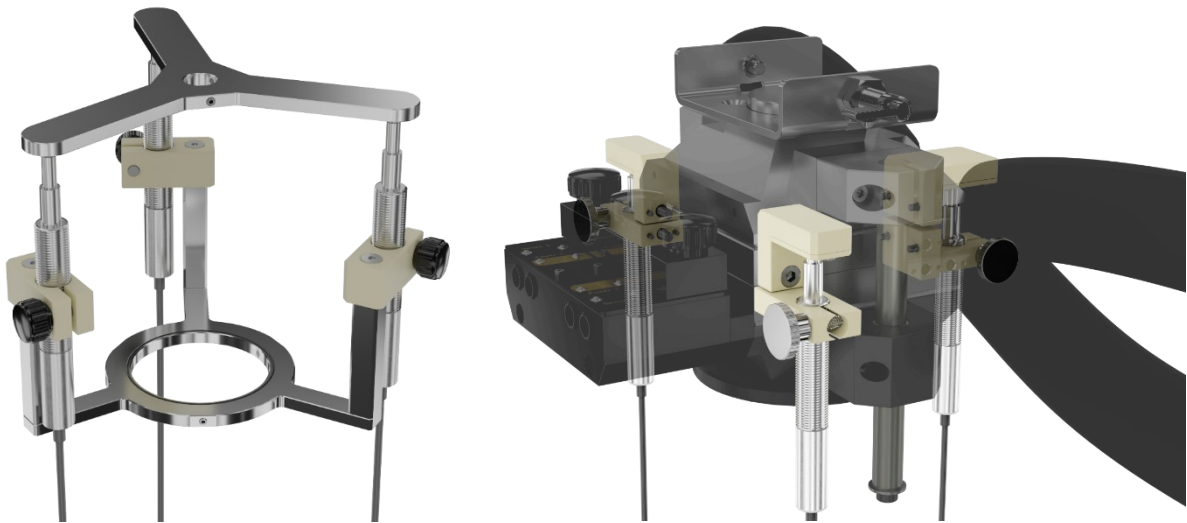

Version 1.4 EN

06/2026

rhd instruments GmbH & Co. KG

Contents

1	Product description	1
2	General information	2
3	Important general safety notes	4
4	Components of the Distance add-on	6
5	Operation conditions, storage and rated values	10
6	Essential features at a glance	11
7	Getting started	12
	7.1 General instructions	12
	7.2 Input connectors	12
	7.3 Voltage Ranges	12
	7.4 Averaging filter	12
8	Initial software setup	13
	8.1 Prerequisites	13
	8.2 RHD.Distance.Server	13
9	Hardware setup and handling	18
	9.1 Cylindrical cells	18
	9.2 CompreCell Pouch	27
	9.3 ComprePouch	41
10	Usage	49
	10.1 System warm-up	49
	10.2 Absolute vs. relative measurements	49
	10.3 Calibrating force + temperature changes	49
	10.4 Constant distance mode in CompreDriveControl	50
11	Troubleshooting	51
	11.1 No data connection to the Multi Data Sampler	51
	11.2 Invalid sensor readings	51
	11.3 High noise on the signal	51
	11.4 Sensor data is not transferred to CompreDriveControl	51
12	Settlement	52
13	Contact and Technical Support	53

1 Product description

The LVDT Distance-Addon is designed to enable the electrochemical characterization while precisely monitoring the thickness changes of the sample during measurement. The product is designed to be used only in combination with the corresponding measuring cells and cell holders produced by rhd instruments. The small and light-weight sensors are connected to the RHD Multi Data Sampler. The data is transferred via a serial interface and can directly be recorded alongside with all other data using Com-preDriveControl software.

The LVDT sensor combination offers a total measuring range of 10 mm with a resolution of 0.1 μm .



2 General information

Thank you for your confidence in our products and services. We wish you pleasure and success with your new LVDT Distance-Addon system.

- » **To avoid physical injuries and damages, please read this instruction manual carefully before using the device for the first time.**
- » **Please pay attention to all safety notes in this instruction manual.**
- » **Please keep this manual safe. In case of selling or leaving the device to third parties, please do not forget to hand this manual over as well.**
- » **The operation of the LVDT Distance-Addon should only be performed by properly trained and experienced members of staff.**
- » **The setup is developed to measure sample thickness changes in your CompreCell and ComprePouch electrochemical measuring cells and must not be used for any other purpose.**
- » **To avoid unstable operating conditions and injury, the LVDT Distance setup as well as the individual components should not be used if**
 - **they show noticeable damage,**
 - **they were stored or operated under unapproved conditions (see operational condition, storage and rated values),**
 - **they were exposed to high mechanical stress, exceeding normal usage,**
 - **they were altered by members of staff not authorized by rhd instruments.**

The instructions in this manual were carefully checked for correctness. However, liability for any mistakes in form and content will not be assumed. Additionally, rhd instruments GmbH & Co. KG (in the following declared as rhd instruments) reserves the right to change the setup and design of the products presented and described within this manual. Such changes are necessary to guarantee the continuous development of the products and, thus, the improvement of product quality and reliability.

Markings in this manual

Marking	Meaning
 WARNING	Indicates a hazardous situation which, if not avoided, could result in serious injury or death.
 ADVICE	Indicates potential physical damages and other important information associated with your device.

3 Important general safety notes

- » Connect the power supply according to the safety regulations for electrical equipment. Otherwise, there is risk of injury, damage to or destruction of the sensor and/or the controller
- » The supply voltage must not exceed the specified limits to avoid damage to or destruction of the sensor and/or the controller
- » Only use the original parts included in delivery. They are prepared for your device and guarantee the necessary safety for operator and device.
- » Do not operate the device with wet hands. Operate the device only in dry rooms.
- » Do not operate the device outdoors.
- » Please follow only the instructions in this manual for cleaning the device.
- » Make sure that cables and conductors are not damaged. Damage could be caused by heat, impact, contact with chemicals, or mechanical impacts like rubbing, bending, tearing and rolling-over.
- » Prevent the devices from mechanical impact. In case the device fell down, please contact rhd instruments or a technician authorized by rhd instruments before switching it on again.
- » If your devices show any visible damage or defect: Disconnect the power supply by pulling out the power connector. Never operate your devices in a damaged state. Never repair the devices on your own. The devices should only be repaired by either rhd instruments or by a technician authorized by rhd instruments.
- » Do not open the Multi Data Sampler. There are no user-serviceable parts inside.
- » Please follow this instruction manual for maintaining your device.
- » Only use original spare parts delivered by rhd instruments.
- » Handle the sensors with care. The sensors should not be exposed to heat or moisture. Prevent mechanical impact on hard surfaces. Do not sideload.



ADVICE: Connect and disconnect any cable connection carefully.



ADVICE: Handle chemicals with care.

- » When handling chemicals during preparation and execution of measurements with the LVDT Distance add-on, the usual safety advice in accordance with the H, EUH, and P statements (in the European Union: rating principles according to the CLP regulation) and appropriate safety measures have to be observed. This applies to subsequent cleaning and decontamination as well.



ADVICE: Sufficient cleaning increases the lifetime of your system.

- » After using the add-on for electrochemical measurements, all components in contact with chemicals need to be thoroughly cleaned. Insufficient cleaning, decontamination, and drying of the components may result in damage due to corrosion and, thus, may affect the quality of your measurement results.

4 Components of the Distance add-on

- » Please unpack your devices carefully.
- » Please check if the delivery is complete:
- » Please check if the delivered items are undamaged.

	<p>ADVICE: If the delivered items are incomplete or damaged, please contact rhd instruments via e-mail (info@rhd-instruments.de) or via phone (+49-6151-8707187).</p> <p>rhd instruments will reject any claims for warranty or responsibility in case damaged equipment is used.</p> <p>In case any accessory of other manufacturers is used, rhd instruments will accept no liability.</p>
-----------------------------------------------------------------------------------	----------------------------------------------------------------------------------------------------------------------------------------------------------------------------------------------------------------------------------------------------------------------------------------------------------------------------------------------------------------------------------------------------------------------------------------------------------------

General equipment:

- 1x Multi Data Sampler
- 1x power supply unit 24 V
- 1x 2m serial cable
- 1x USB to serial adapter
- 1x manual "Multi Data Sampler"
- Various accessories

122 Cylindrical cell package:

- 1x lower assembly aid
- 1x stand for 3 LVDT sensors
- 3x LVDT sensors
- 1x sensor holder
- 1x hex screw driver (1.5 mm)

To be ordered separately:

- 1x Upper plate (cantilever) and auxiliary equipment for LVDT Distance add-on (either 12, 10 or 6 mm) for CompreDrive or CompreFrame setups
- Low profile Lid CompreCell 12/10/6

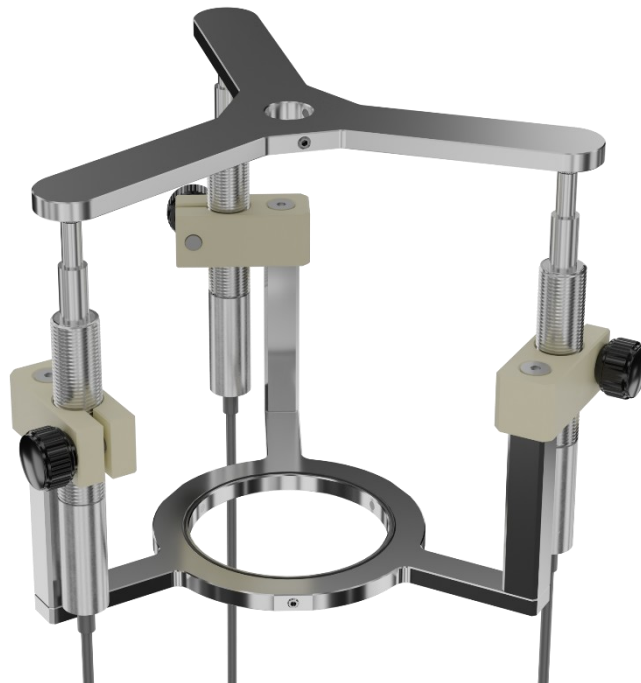

Figure 1: Sensor holders, spacers and sensors for cylindrical cells.

124 CompreCell Pouch package:

- 3x LVDT sensors
- 2x front sensor holders and deflectors
- 1x rear sensor holder and deflector
- 8x fixation screws (4x ISO4762 M5x12, 4x ISO10642 M3x14)
- 3x thumb screw

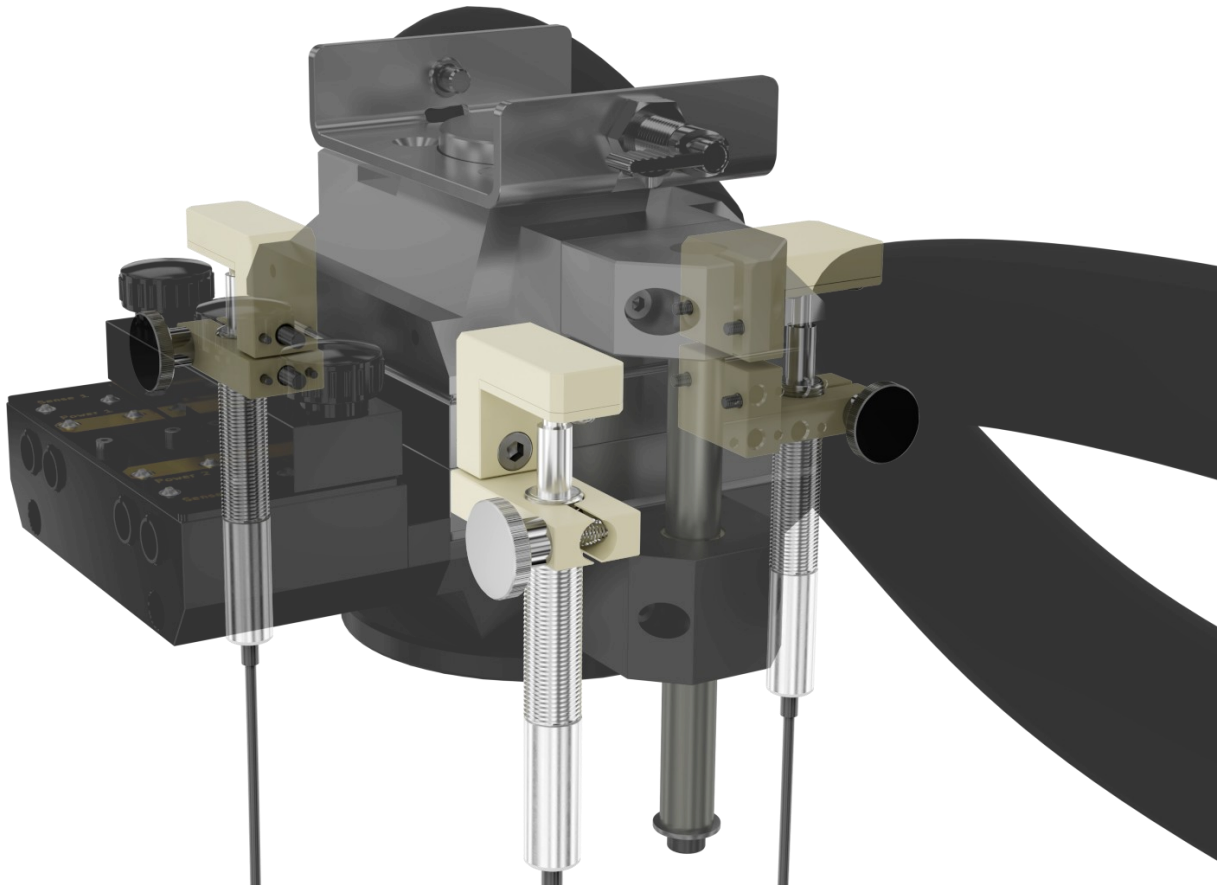

Figure 2: Sensor holders and deflectors on CompreCell Pouch.

ComprePouch package:

- 2x LVDT sensors
- 2x sensor insertion sleeves
- 1x 2 mm hex screwdriver
- ISO4026 M4x5 set screws

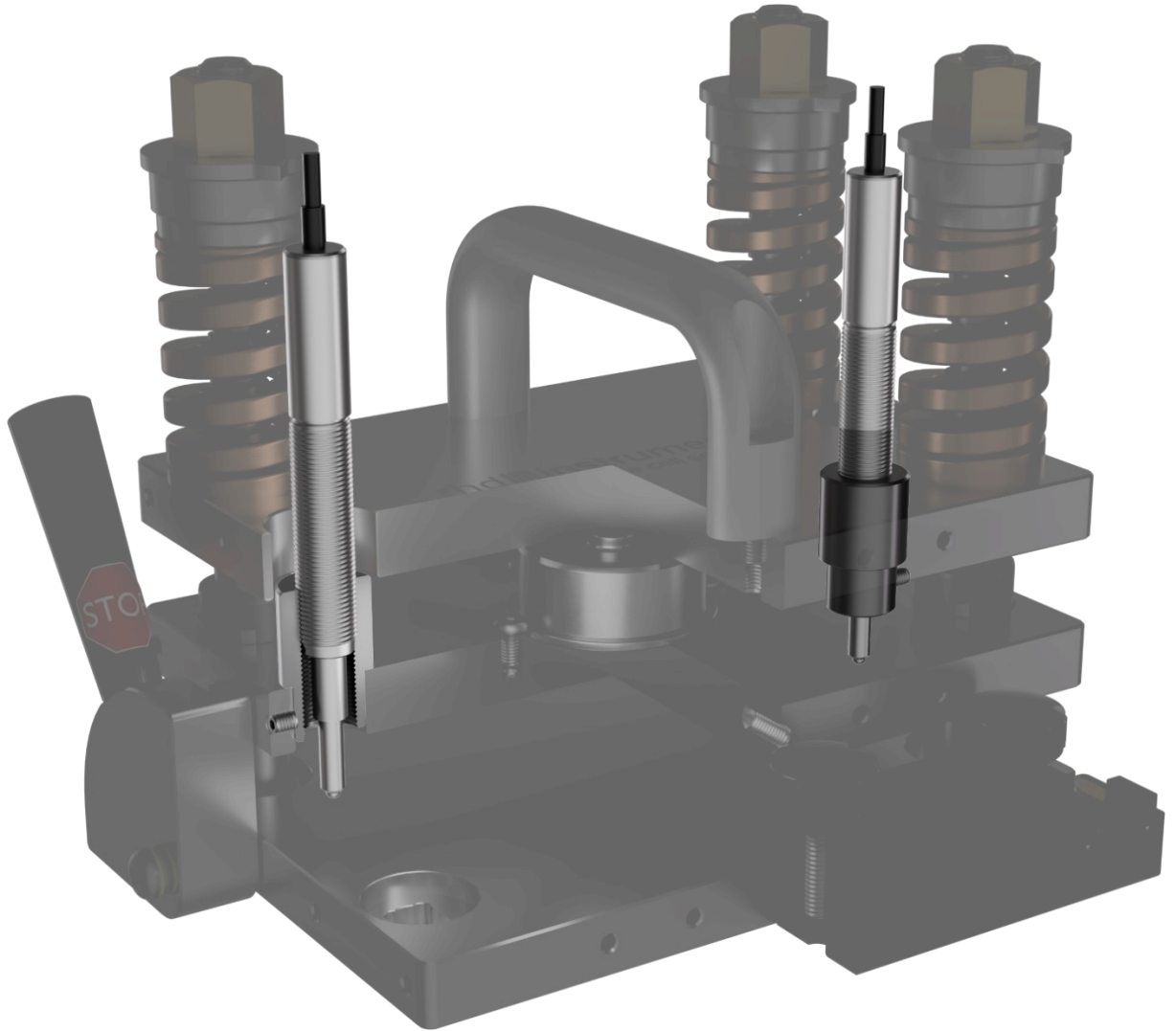

Figure 3: Sensor holders on ComprePouch

5 Operation conditions, storage and rated values

- » Temperature range during operation $T_{env. operation} = -25\text{ °C to }+85\text{ °C}$, low humidity, not freezing.
Sensor:
- » Temperature range during storage $10\text{ °C to }30\text{ °C}$
Sensor:
- » Atmosphere during storage: Non-corrosive

LVDT sensor characteristics

Measuring range	10 mm
Spring constant	0.2 N/mm
Linearity (displacement and distance measurement)	<+-0.25% F.S.
Temperature coefficient	+0,4 % FS / 10K
Output ripple	<5 mV RMS

6 Essential features at a glance

- » High-precision distance measuring system for cylindrical CompreCells and pouch cells with respective cell holder.
- » Measurement of sample thickness changes during electrochemical experiments.
- » Measuring points as close to the sample as technically possible, to exclude influences from the main pressure frame (not applicable to ComprePouch).
- » Robust assembly and handling.
- » Fully included data handling and processing into CompreDriveControl software.
- » Retrofittable to all CompreDrive and CompreFrame systems.
- » Addons for CompreCell and CompreCell Pouch are compatible with CompreDrive HC and H temperature control options.
- » Addon for ComprePouch is compatible with climate chamber use.

Note:

If you have any questions, for example with regard to the compatibility of your measurement devices, do not hesitate to contact us via email (info@rhd-instruments.de) or phone (+49-6151-8707187).

7 Getting started

The Distance Addon consists of the Multi Data Sampler hardware, a set of LVDT sensors and a set of sensor holders and accessories. For each different application the hardware setup and handling is treated in a section of chapter 9. On the software side, two applications are needed to run the setup: RHD.Distance.Server handles the signal acquisition and CompreDriveControl is used for data display and processing.

7.1 General instructions

Connect the 24 V power supply to the DC input jack at the back of the device. Connect the serial connection cable between the serial connector at the back of the device and the computer. Use the USB-Serial adapter if the computer does not have a native serial port.

Switch the device on using the switch at the back of the device.

The status LED at the back lights green to indicate operation.

7.2 Input connectors

The LVDT sensors are shipped with 4-pin LEMO connectors. The connectors have a push-pull design and must not be rotated when inserted. The pins are assigned according to the table below.

7.3 Voltage Ranges

Each channel of the Multi Data Sampler can be set to one of 6 voltage ranges, or be disabled. At least one channel must be enabled at all times.

Note that only the **0-10V** range is needed for the applications described in this manual. Make sure to always set the channels to 0-10V or disable unused channels.

7.4 Averaging filter

Internally the input voltages are sampled at 1 kHz. The user can select averaging between 1 and 256 values. Depending on the selection, the given number of values are block-averaged, reducing the internal data rate to 1 kHz / N.

Please note: The maximum data rate available to the computer is further limited by the serial interface to a maximum of roughly 50 Hz.

8 Initial software setup

8.1 Prerequisites

Your distance addon works particularly well in combination with CompreDriveControl, as CompreDriveControl provides easy access to the data through a user-friendly interface.

Please install CompreDriveControl before installing the RHD.Distance.Server.

8.2 RHD.Distance.Server

8.2.1 General description

The RHD.Distance.Server is a signal acquisition software that is used in conjunction with a Multi Data Sampler to run dilatometry measurements.

The sensor data is transmitted to CompreDriveControl in the background when both applications run on the same computer. You can inspect the data in the manual control plots window in CompreDriveControl by selecting the MDS LVDT or Center Distance data stream from the Y1 and Y2 dropdown menu.

8.2.2 Installation

The distance addon installer is named like this:

`rhd-ds-setup-<version>.exe`

Execute the installer and follow the instructions to install the program. By default, administrator privileges are not required. The software is installed into the %localappdata% directory by default.

After the installation, the program can be started with one of the created shortcuts in the start menu or on the desktop.

To uninstall the program, run the Uninstall program from the Start menu, or from the Windows application settings.

8.2.3 Connecting to the device

After starting RHD.Distance.Server navigate to the MDS-LVDT #0/Device Setup tab. Refresh the device list, select the appropriate serial device and click connect. If you are

using a serial-to-USB adaptor provided by rhd instruments you can identify the device by the serial number displayed in the dropdown menu.

8.2.4 Device settings

In the device settings menu channels can be activated or disabled. Activate the channels that you plan to connect to LVDT sensors. The voltage range should be set to **0-10V**. The filter amount parameter, as described in section 7.4 can be freely chosen. We recommend to average over 64 or 128 values.

After you adjusted the settings click apply. You can click reload, which loads the settings from the Multi Data Sampler, to check if the settings were written to the device correctly.

8.2.5 Range Setup

The range setup in the device setup ribbon shows the current state of the connected sensors. Free standing sensors are out of range by default at the low end of the range. When the sensors are pushed all the way in, the range will be at 100%.

	ADVICE: Exceeding the range does not trigger any visual or audible warning, so sensors should be handled with care when approaching 100%.
-------------------------------------------------------------------------------------	--------------------------------------------------------------------------------------------------------------------------------------------------

For some steps in the sensor handling it is advised to monitor the deflection in the range setup window (see chapter 9).

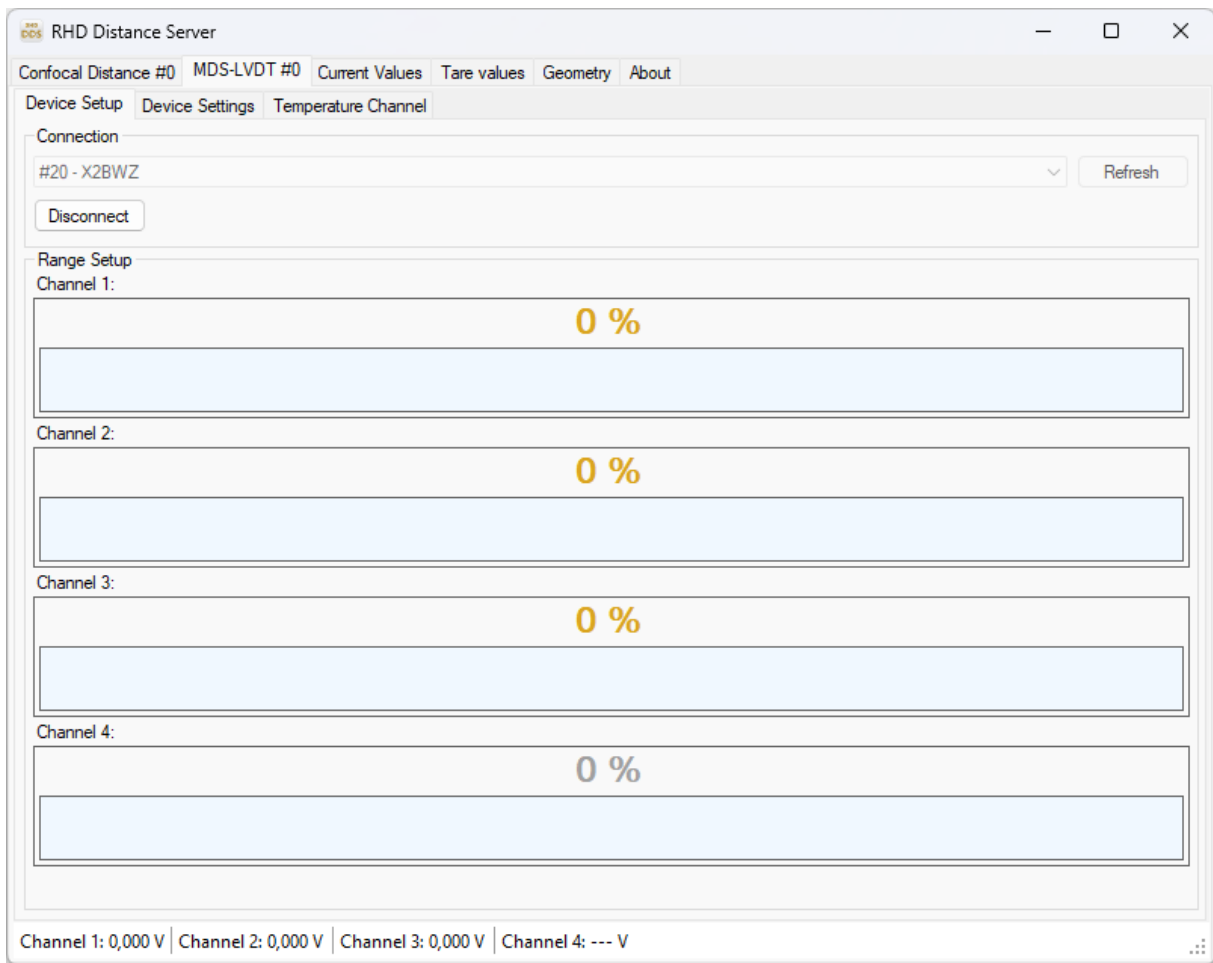

Figure 4

8.2.6 Geometry

The RHD.Distance.Server can calculate a center point distance signal from multiple sensor inputs when the specific geometry is provided. Currently, linear and trigonal geometries are supported, the former being used for the ComprePouch and the latter being used for cylindrical cells and CompreCell Pouch setups. For each different setup there are presets to be chosen using the preset button (see chapters 9.1, 9.2, 9.3).

The RHD.Distance.Server works with LVDT sensors and confocal sensors. **You have to select the sensors you are using in the dropdown menus on the left side in the geometry ribbon.**

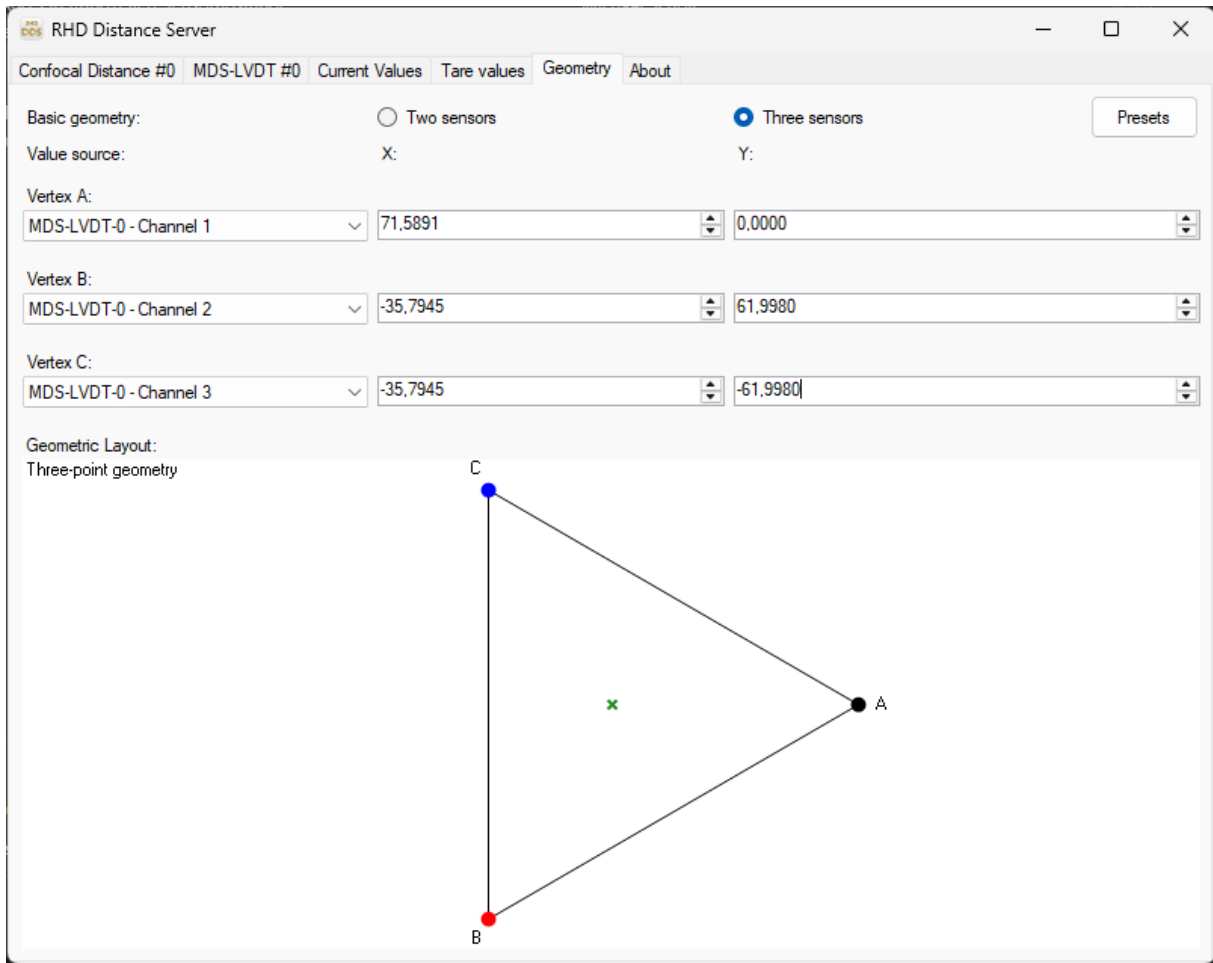

Figure 5: Geometry view with presets for CompreCell 6/12.

When the geometry tab is fully configured, the RHD.Distance.Server will transmit the Center Distance value to CompreDriveControl in the background, which can be inspected in the manual control plots window of CompreDriveControl.

Note that the assignment of the vertices to the sensor channels needs to be correct for accurate calculation of the Center Distance.

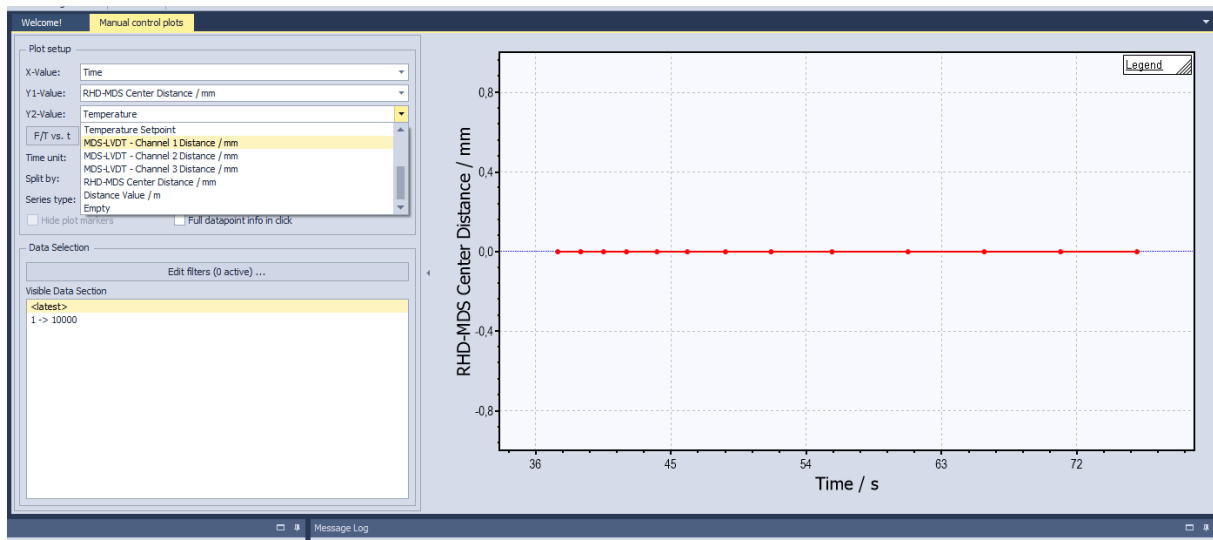

Figure 6

While the RHD.Distance.Server stores the last settings, you should always check if the settings are correct before starting your measurement.

9 Hardware setup and handling

9.1 Cylindrical cells

The LVDT distance add-on needs to be mounted on the cell you plan to use ahead of the measurement.

9.1.1 Hardware preparation

Prepare the setup by connecting the LVDT device to the computer, then proceed to mount the sensor holders. Connect the sensors to the Multi Data Sampler, connect the Multi Data Sampler to the computer, connect the 24V power supply and switch the device on.



Note: The connectors on the sensors are push-pull-connectors, which must only be pushed or pulled on the shrink wrapped part, not screwed or twisted!



Figure 7: Connect the sensors to the RHD Multi Data Sampler. Connect the Multi Data Sampler to the computer using RS-232 or USB via the adaptor, connect the 24V DC power supply and switch on.

Start the RHD Distance server software and connect the device (for initial software setup refer to chapter 8. Navigate to MDS-LVDT #0, select the appropriate COM device and click the connect button.

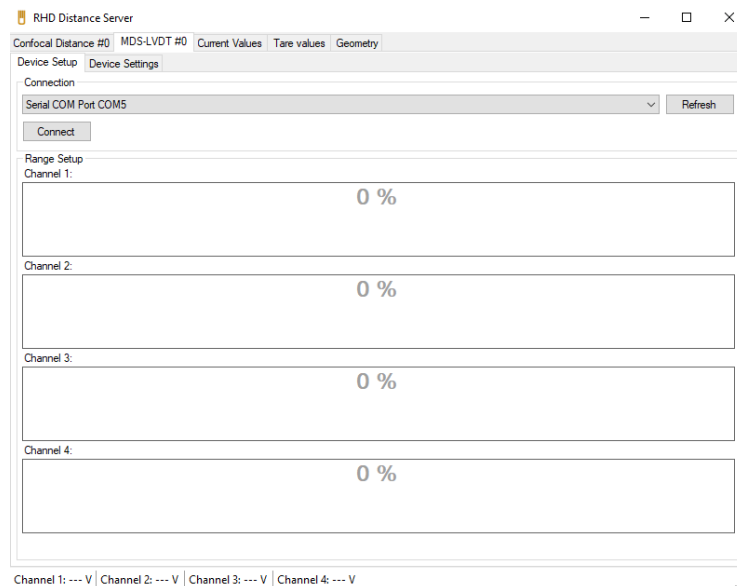

Figure 8: Start the RHD.Distance.Server application, navigate to the LVDT ribbon and select the appropriate COM device.

9.1.2 Initial sample height

If you are interested in the absolute thickness of your sample, we recommend determining your sample height at this point in time. See chapter 10 for more information about absolute vs. relative measurements and other caveats of distance measurements.

9.1.3 Sensors + sensor mounts

Place the bottom sensor holder on top of the bottom mounting aid and insert your CompreCell into the mould in the middle. Use the 1.5 mm hex key to tighten the screws. Arrange the cell as seen in the picture (Pt100 sensor drillhole in front), otherwise you will not be able to insert the temperature probe. Also make sure that the grub screws do not contact the indents of the bottom plate but the protrusions.

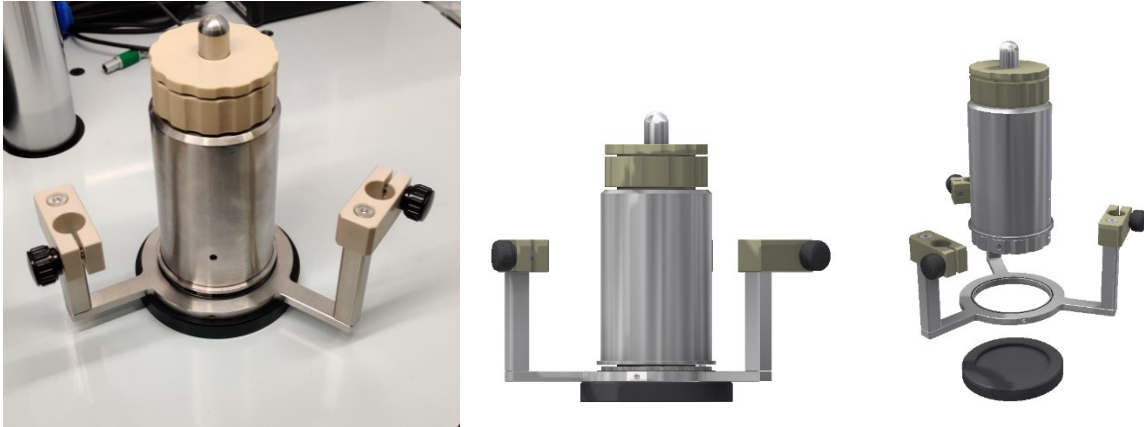

Figure 9: Place the bottom mounting aid on a flat surface, place the bottom sensor holder on it and insert the CompreCell into the cavity.

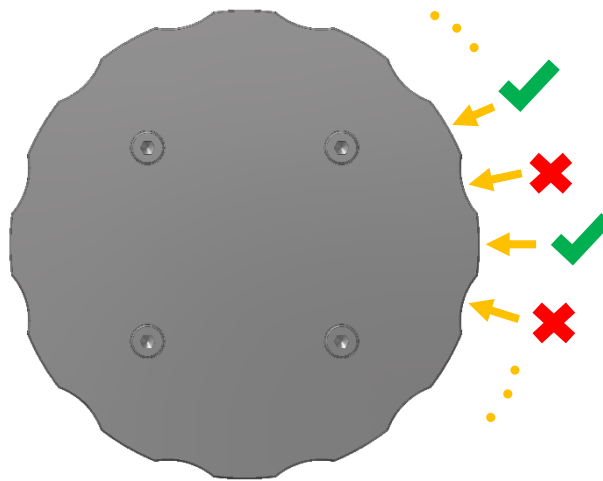

Figure 10: Grub screws should contact protrusions, not indents

Now move the cell to the CompreDrive or CompreFrame. **If you are using a CompreDrive, the cell fixation (steel rod and bracket) needs to be removed before mounting the cell on the platform.**

Slide the thermal jacket on the cell, making sure that no parts of the sensor holder touch the thermal jacket or the hoses. Place it altogether on the platform of the CompreDrive or CompreFrame. Insert the temperature sensor (Pt100) into the CompreCell. Make sure that the temperature sensor does not touch parts of the LVDT device.



ADVICE: Make sure that the LVDT sensors do not touch the metal frame of the sensor holder, the cell body, the thermal sleeve and hoses or the temperature sensor. Contact may lead to damage to your sample or damage to the sensors and Multi Data Sampler (AD converter). Reason is, that the sensors are connected to the ground of the Multi Data Sampler.

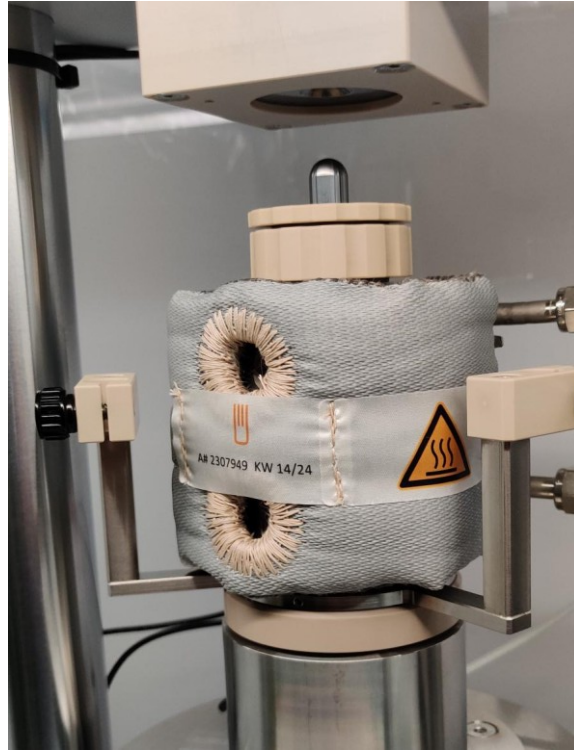

Figure 11: Placement of the cell on the CD stage with attached thermal sleeve and sensor holders.

Slide the upper cantilever on the top piston. Leave an air-gap of approximately 2 mm to the PEEK lid. Use the fitting cantilever placement aid to adjust the airgap between the lids and the cantilever. Select the placement aid according to the lids and cell pistons in use (see table below). If using short lids (Figure 12, mandatory for CompreFrame), use the long cantilever placement aid and vice versa.

		Pressure Frame	
		CD = CompreDrive	CF = CompreFrame
Piston diameter	6 mm	D6 CD	D6 CF
	10 mm	D10 CD	D10 CF
	12 mm	D12 CD	D12 CF

Before tightening the grub screws gently rotate the cantilever to align it with the bottom sensor holders. Tighten the grub screws to fix the cantilever to the piston. Afterwards, remove the cantilever placement aid.

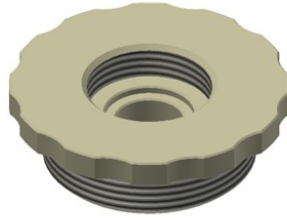



Figure 12: Low profile lid for use with CompreFrame. Optional for use with CompreDrive.

	<p>CAUTION: If you are using the distance addon with a CompreFrame you need to replace the standard double lid assembly with a short lid, delivered with the addon in case you ordered it for use with a CompreFrame. Failure to do so may lead to damage to the CompreFrame, Distance Addon and your Cell.</p>
	<p>ADVICE: Make sure that the top cantilever does not touch parts of the CompreDrive during approach or operation. Mount the cantilever with appropriate clearance. Failure to do so may result in unusable distance data, damage to the LVDT sensors and the cell and CompreDrive device.</p>

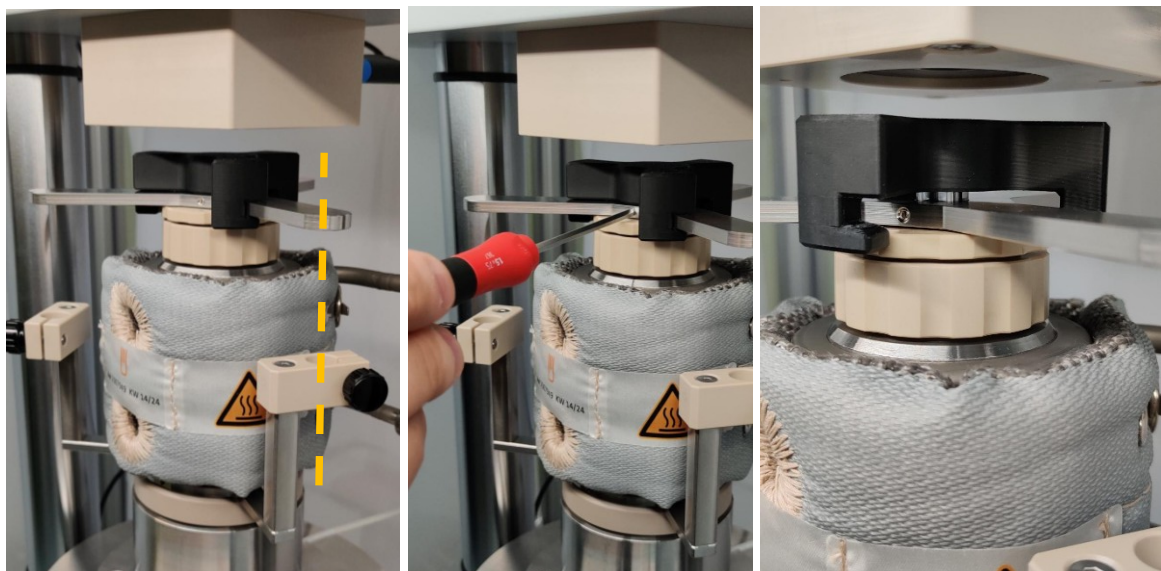



Figure 13: Align the top cantilever with the sensor holders before tightening the screws. Do not rotate the cantilever afterwards.

9.1.4 Approach + Tare

Close the CompreDrive door and use the approach procedure of CDC, which will set the force to 30 N initially. If you are using a CompreFrame, adjust the initial force to 150 N. **Monitor the position of the cell during the approach. If it is tilted or not properly inserted into the PEEK ring of the platform immediately retract and realign the cell.** After the approach completed, check the cell alignment and make sure it is properly inserted in the PEEK ring of the platform.

	<p>CAUTION: Make sure not to exceed the working range of the LVDTs during.</p>
-----------------------------------------------------------------------------------	-------------------------------------------------------------------------------------------

Insert the sensors into the bottom sensor holders. Adjust the sensors to a deflection of 30-40% and clamp them in place by tightening the thumb screws.

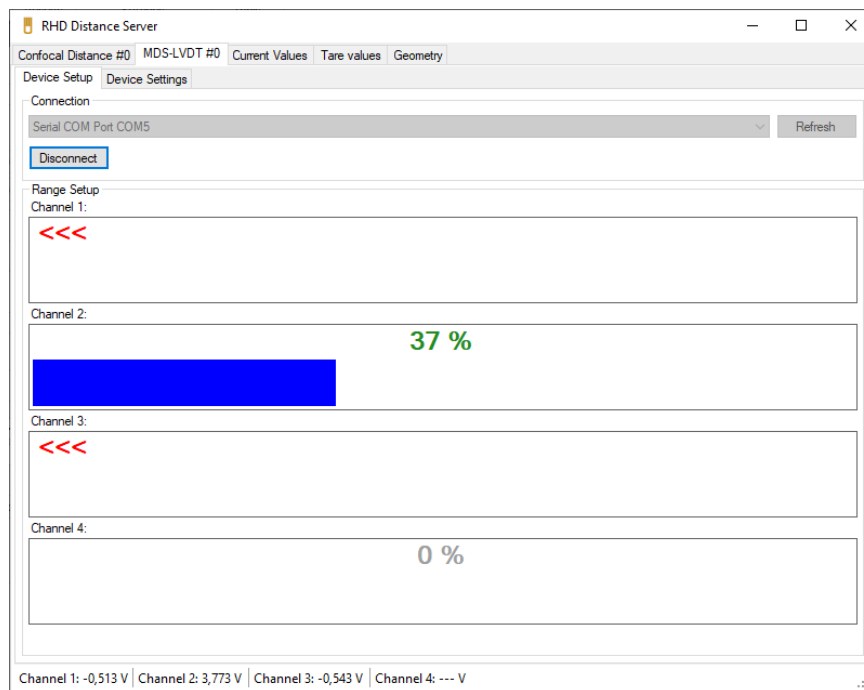



Figure 14: Sensor view of the distance server application.

	<p>CAUTION: Make sure not to exceed the working range of the LVDTs during operation. If you have a large sample or expect large dilatation for any reason, set the initial sensor deflection to low values (e.g. 10%) to maximize the remaining working range.</p>
-------------------------------------------------------------------------------------	---------------------------------------------------------------------------------------------------------------------------------------------------------------------------------------------------------------------------------------------------------------------------

Be careful not to exceed the working range of the sensors during operation. The initial pre-compression of the sensors must be subtracted from the full-scale range in order

to obtain the remaining range, e.g. if the sensors are set to 40% at the start of the measurement 6 mm remain for further compression. If large samples at low tap density are compressed or if there is an airgap in the cell after preparation there is a risk of exceeding the working range.

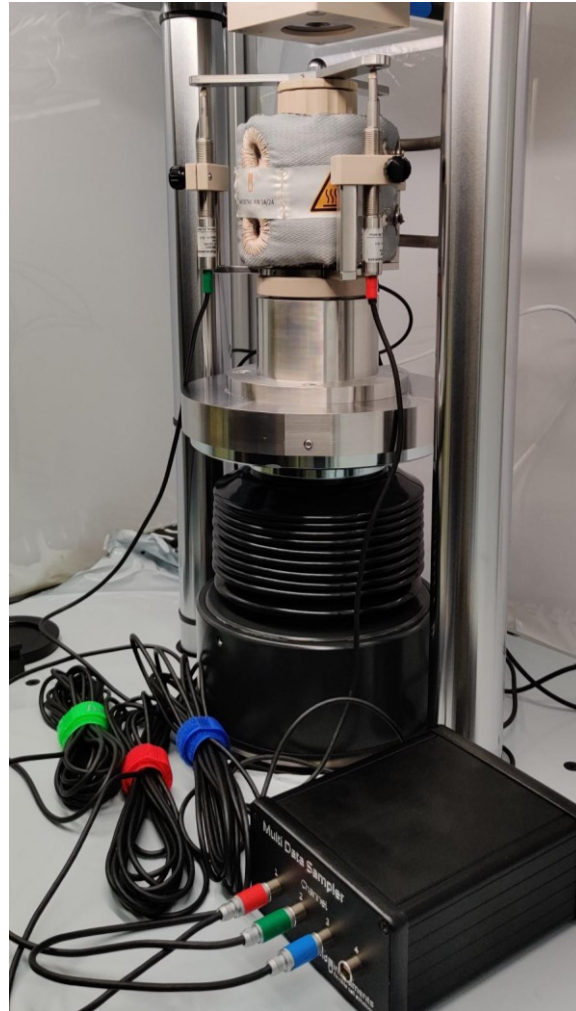

Figure 15: Assembled cell + thermal sleeve + sensor.

Before you start your measurement, or at any necessary point you may navigate to the tare values ribbon and apply a tare value to the sensors. A useful tare value is e.g. the initial cell height mentioned in chapter 9.1.2.

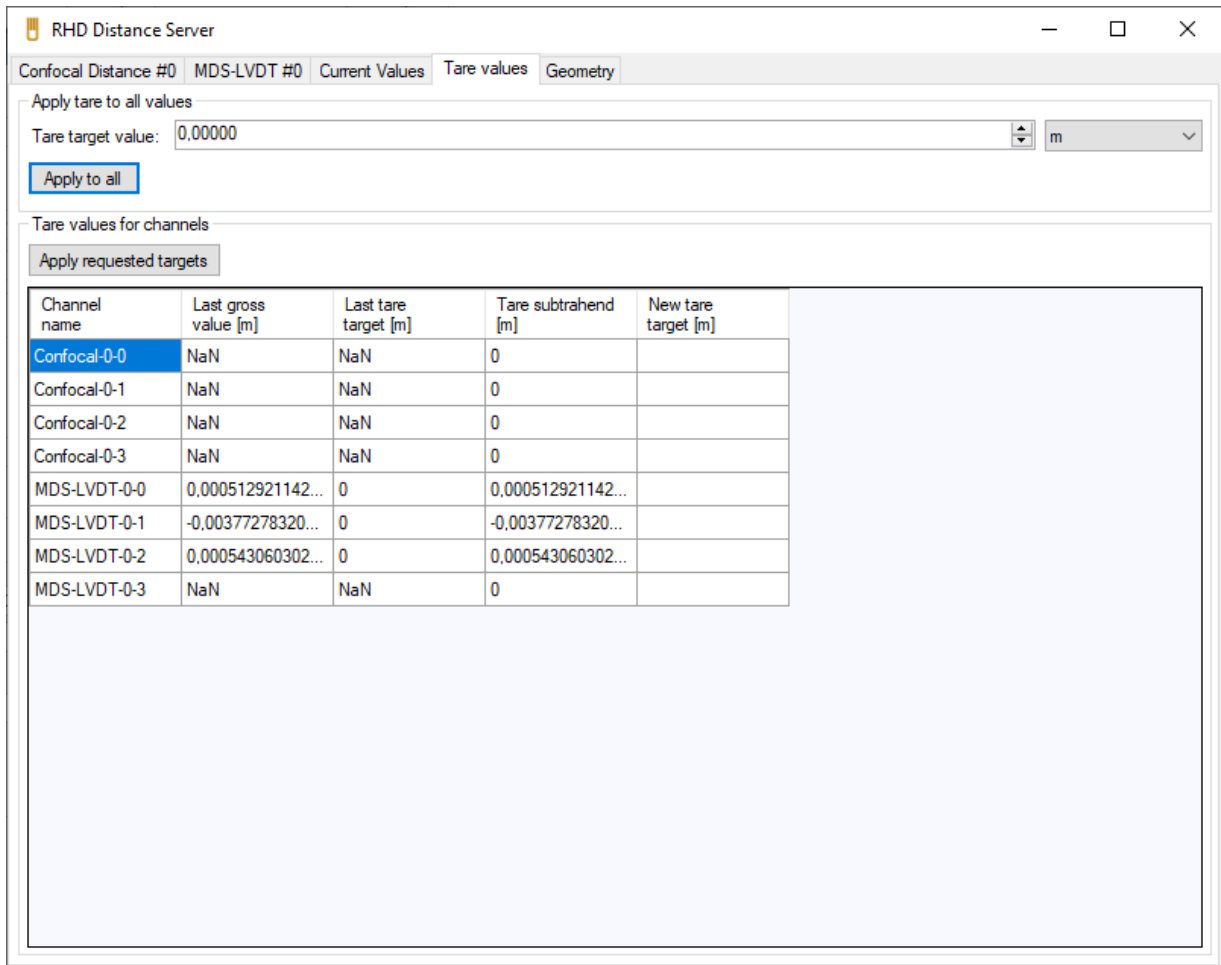

Figure 16: Tare window of the distance server application.

Select the preset for cylindrical CompreCell in the geometry tab and make sure a LVDT channel is selected for each vertex. As the setup is rotationally symmetric, it does not matter which LVDT channel is selected, as long as different channels are selected for each vertex.

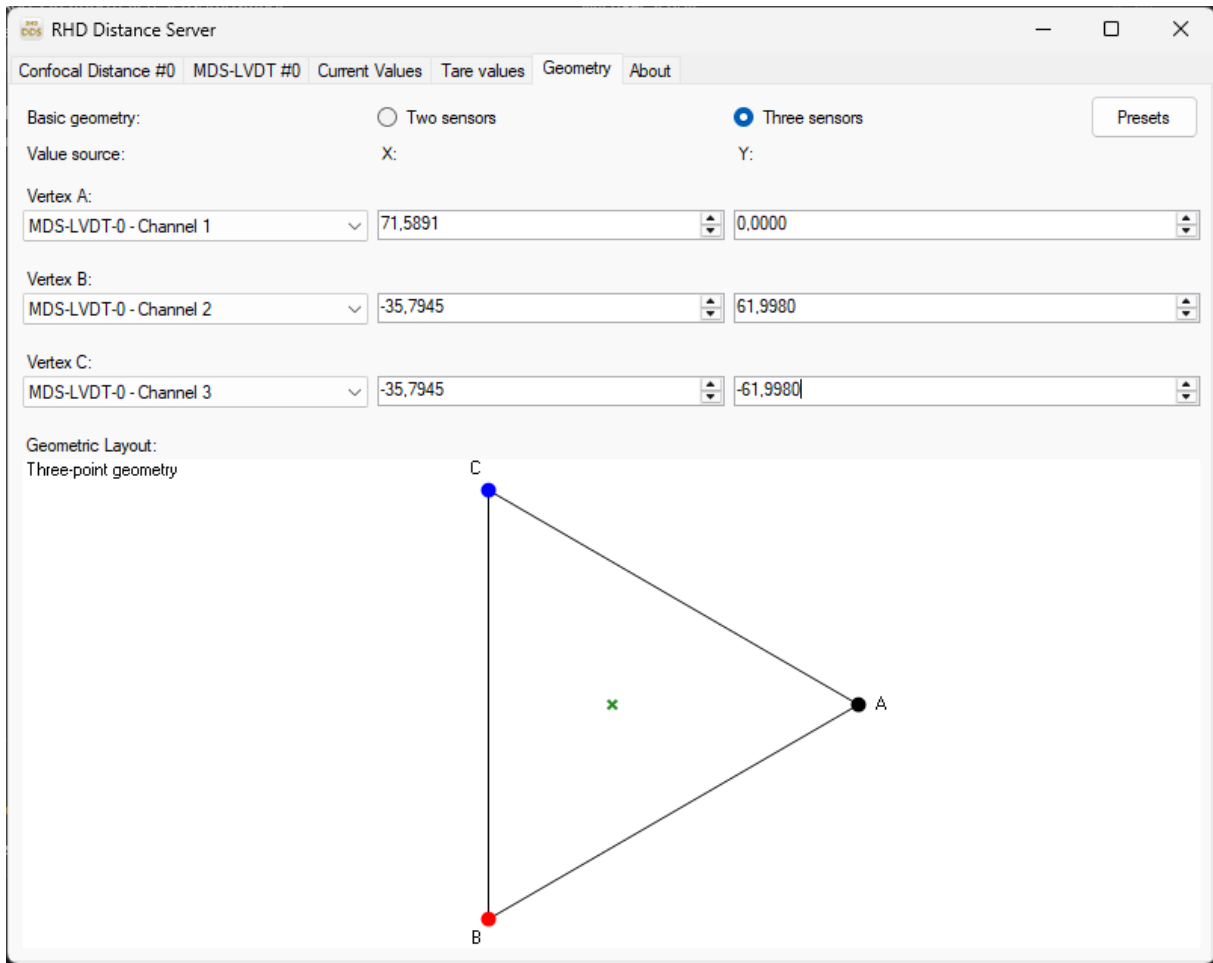

Figure 17: Geometry view with presets for CompreCell 6/12.

For disassembly follow the instructions in reverse order.

9.2 CompreCell Pouch

9.2.1 Installation of the CompreCell Pouch in a pressure frame

The LVDT distance add-on needs to be mounted on the CompreCell Pouch 10S, which needs to be mounted in the CompreDrive or CompreFrame beforehand. Please refer to the corresponding, separate manual for the installation and general handling of your CompreCell Pouch 10S HC.

Note: We recommend installing the rear sensor holder and deflector onto the CompreCell Pouch before inserting it into the CompreDrive if you feel more confident about lifting heavy things precisely than inserting screws without having line of sight to the corresponding screw holes.

9.2.2 Different CompreCell Pouch Versions

The LVDT Distance-Addon was designed for the CompreCell Pouch 10S HC Version 331.3.

It is not fully compatible with older versions of the CompreCell Pouch 10S HC. However, older versions can be reworked for compatibility with the LVDT Distance-Addon. Please feel free to reach out to rhd instruments for more information about this option.

The reworked versions are called 331.1b or 331.2b and have different positions for the two front sensors, see Figure 18 to Figure 21.

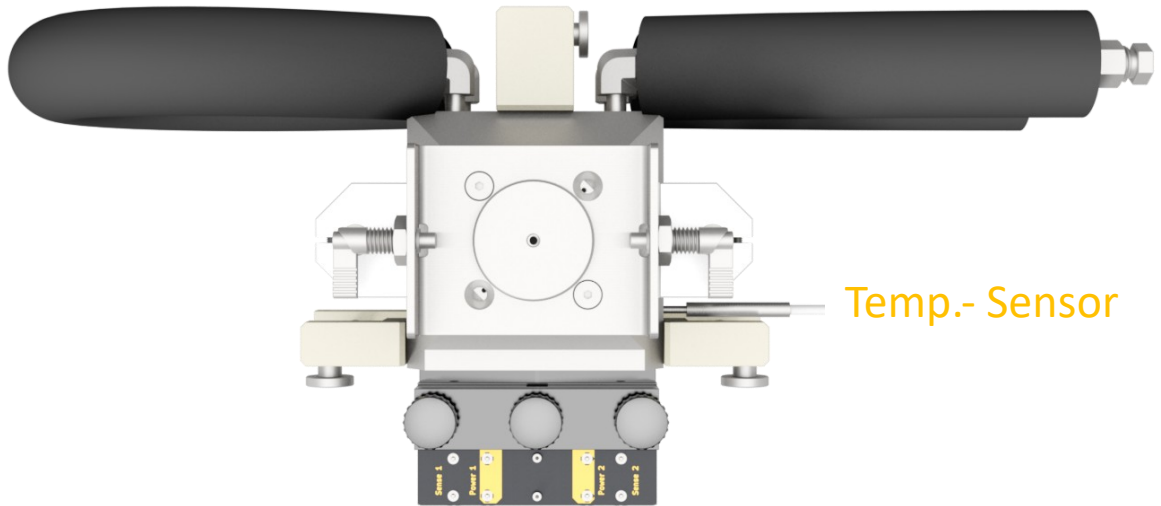

Figure 18: Sensor positions for CompreCell Pouch 105 HC Version 331.3 - Top view

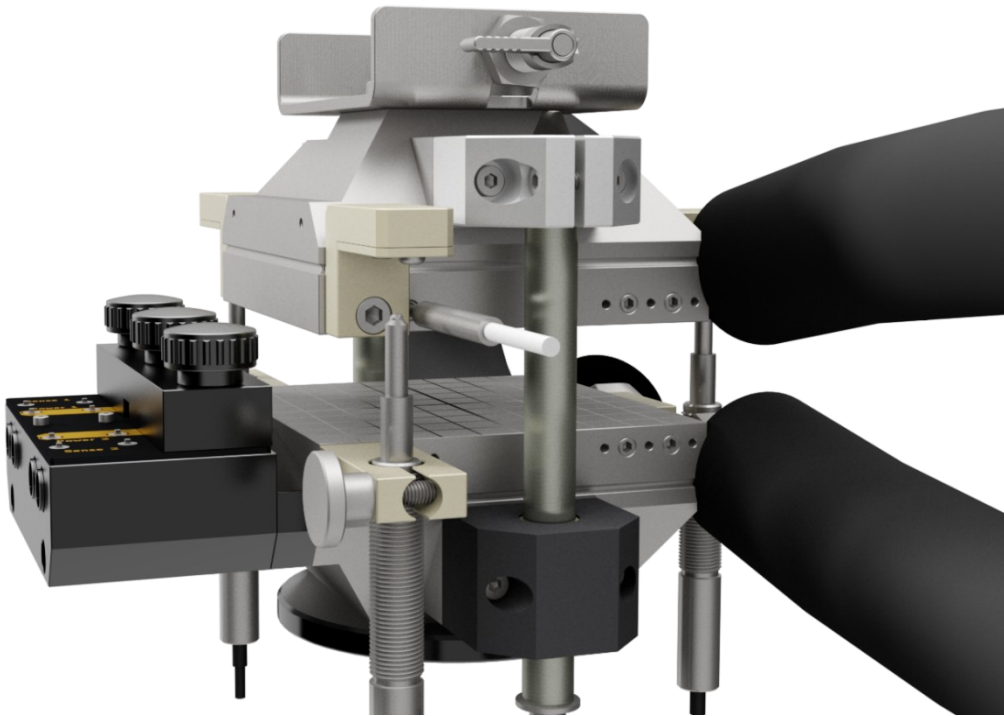

Figure 19: Sensor positions for CompreCell Pouch 105 HC Version 331.3 - Side view

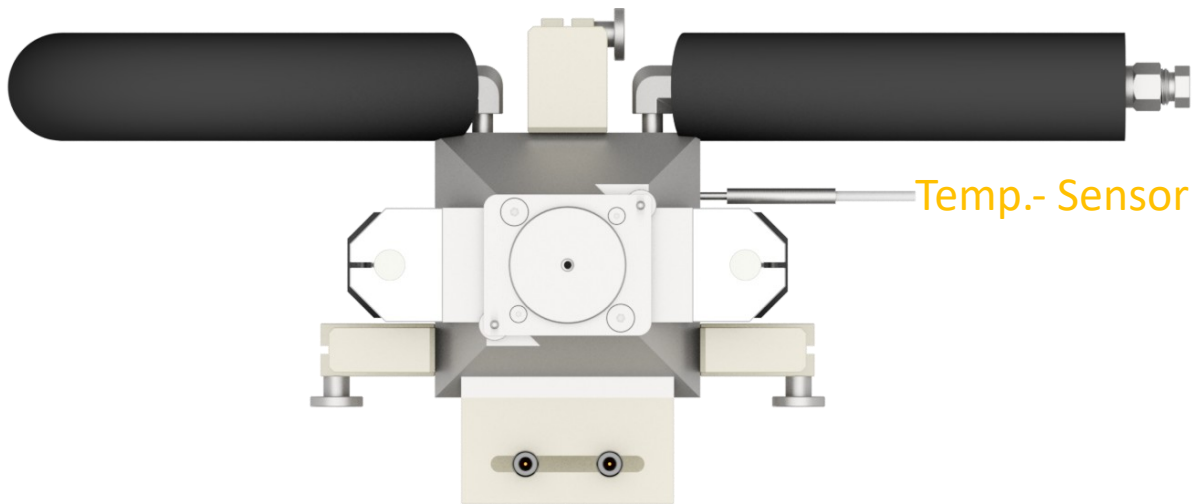

Figure 20: Sensor positions for CompreCell Pouch 10S HC Version 331.2b - Top view

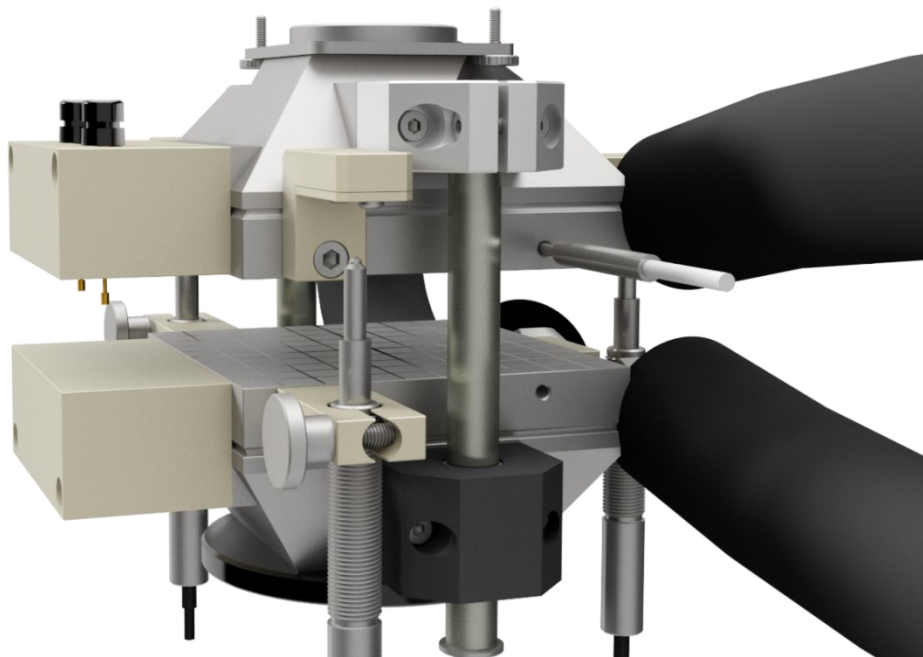

Figure 21: Sensor positions for CompreCell Pouch 10S HC Version 331.2b - Side view

As the installation process is extremely similar for both versions, only version 331.3 is shown in chapter 9.2.3.

Due to the limited space between the 3 rods of the CompreFrame and the slightly different sensor positions of the CompreCell Pouch 10S HC Version 331.2b, the PCB contact solution cannot be used at the same time as the LVDT Distance Addon.

9.2.3 Installation of sensor holders and deflectors

Installation of the LVDT Distance Add-On starts with mounting the included PEEK holders. These sensor holders and deflectors can be installed permanently.



WARNING: Incorrect installation of the sensor holders and deflectors might lead to a crash and can cause permanent damage to your system.

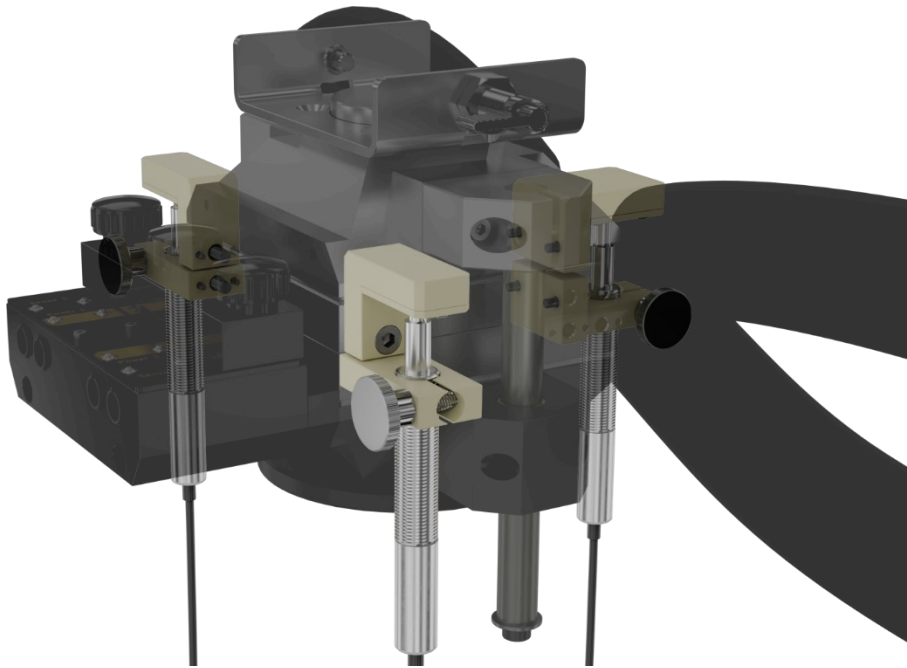

Figure 22: LVDT Distance Add-on for CompreCell Pouch 10S HC

In the CompreFrame, the CompreCell Pouch has to be rotated as shown in Figure 23. The installation steps are explained in detail below, Figure 23 is shown as reference only to make sure you know where the PEEK holders need to be installed relative to the guide rods.

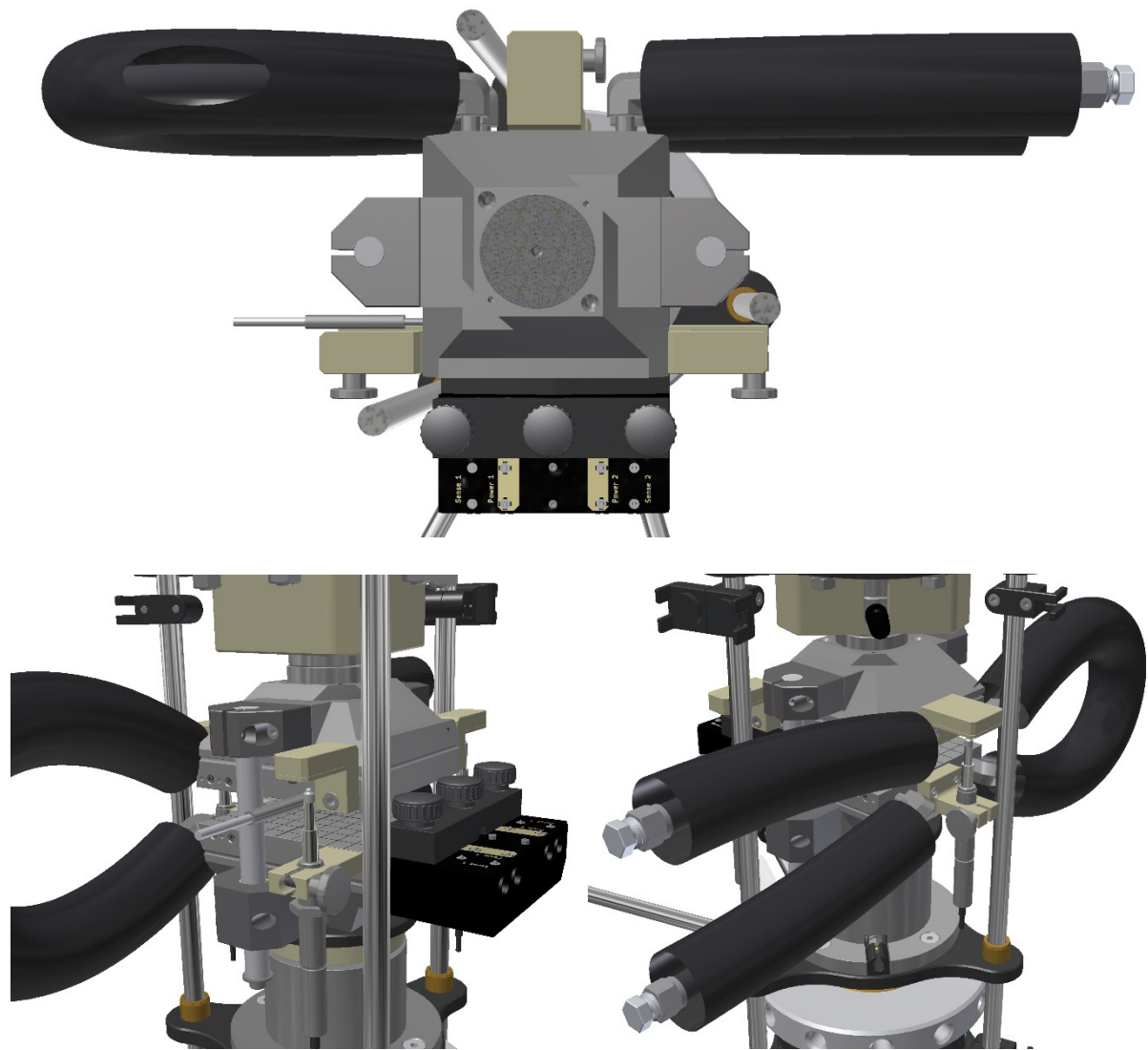

Figure 23: LVDT-Distance Add-On on CompreCell Pouch in CompreFrame

Remove the grub screws out of the 4 front most threaded holes (2 on the left side, 2 on the right side) of your CompreCell Pouch.

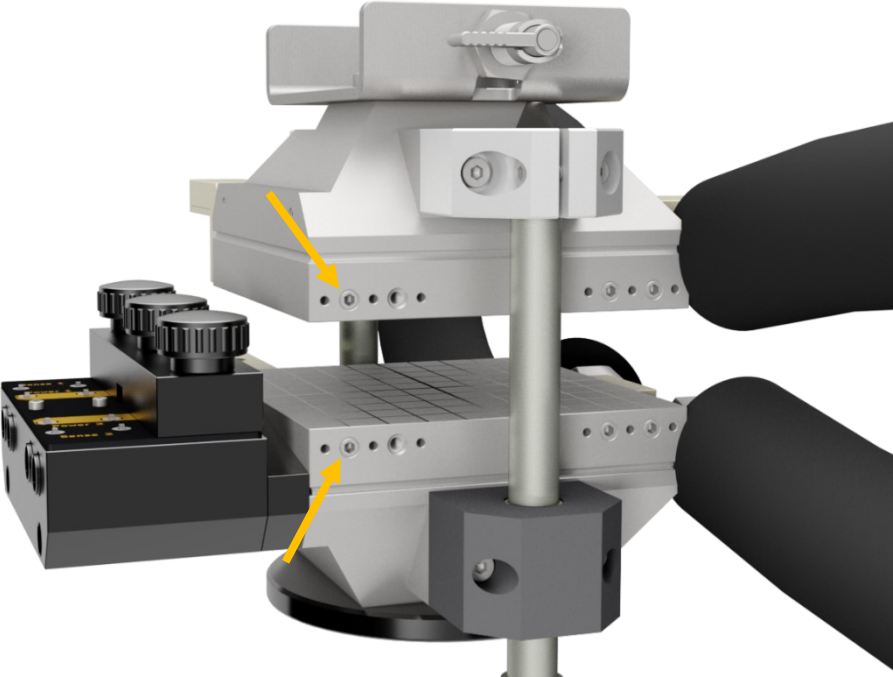

Figure 24

The left and right sensor holders have to be fixed with the M5 screws (included in the package). They have alignment pins that need to be inserted into the corresponding holes on the CompreCell Pouch before tightening the screws.

Make sure that the sensor holders are orientated with the small through hole (without threads) facing towards you.

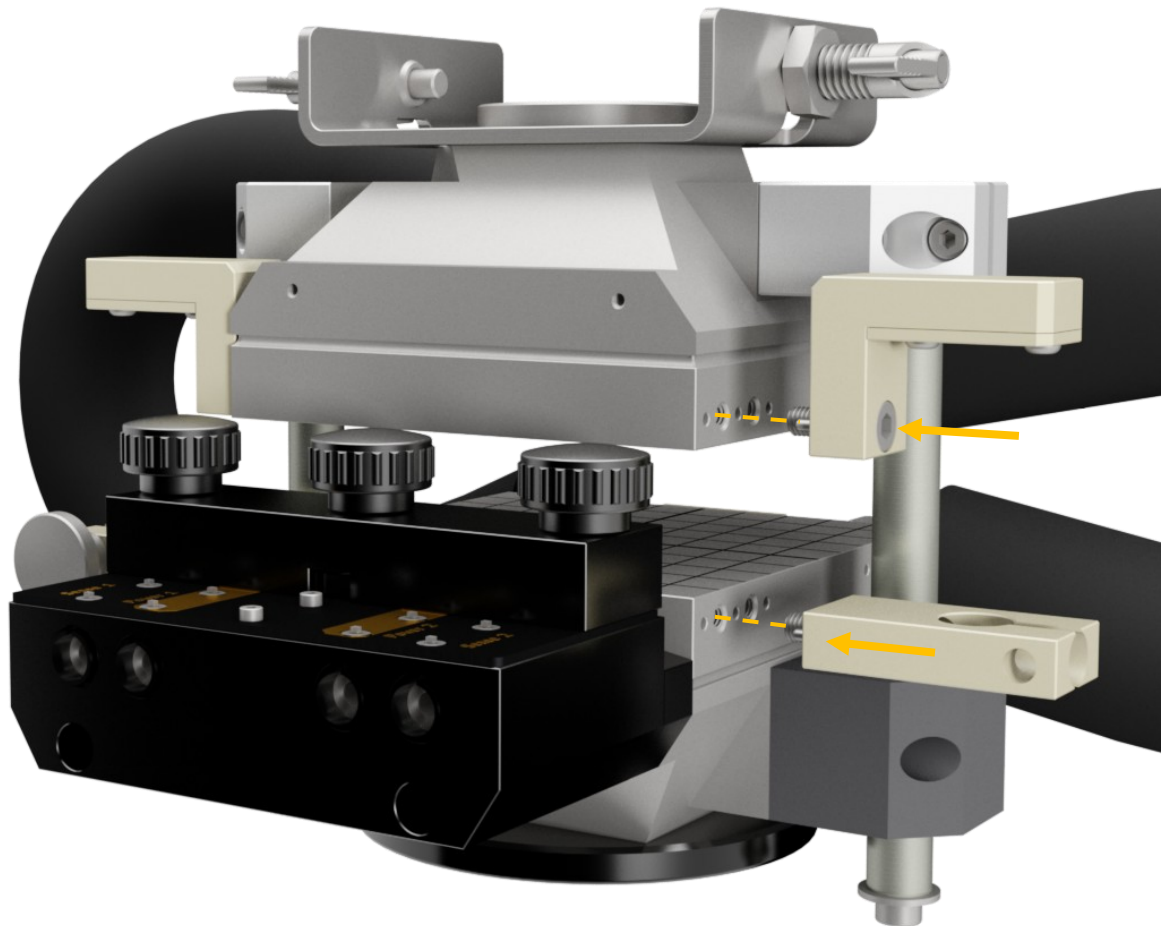

Figure 25

Insert the thumb screws into the left and right sensor holders.

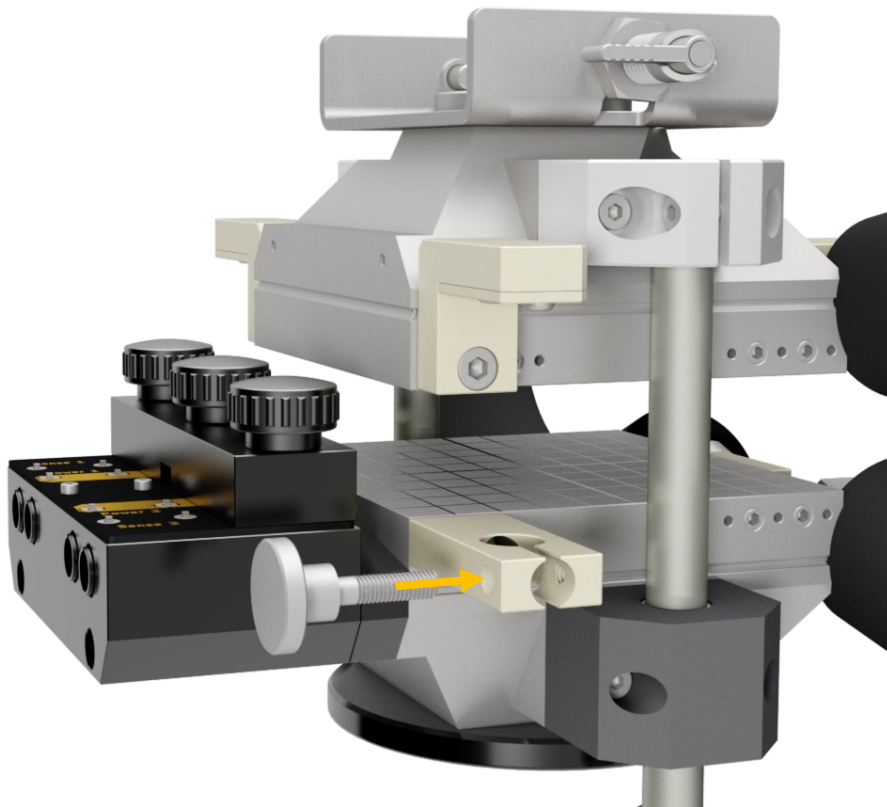

Figure 26

Fix the rear sensor holder and deflector in place with the 4 countersunk screws, while making sure the parts are orientated as shown in Figure 27.

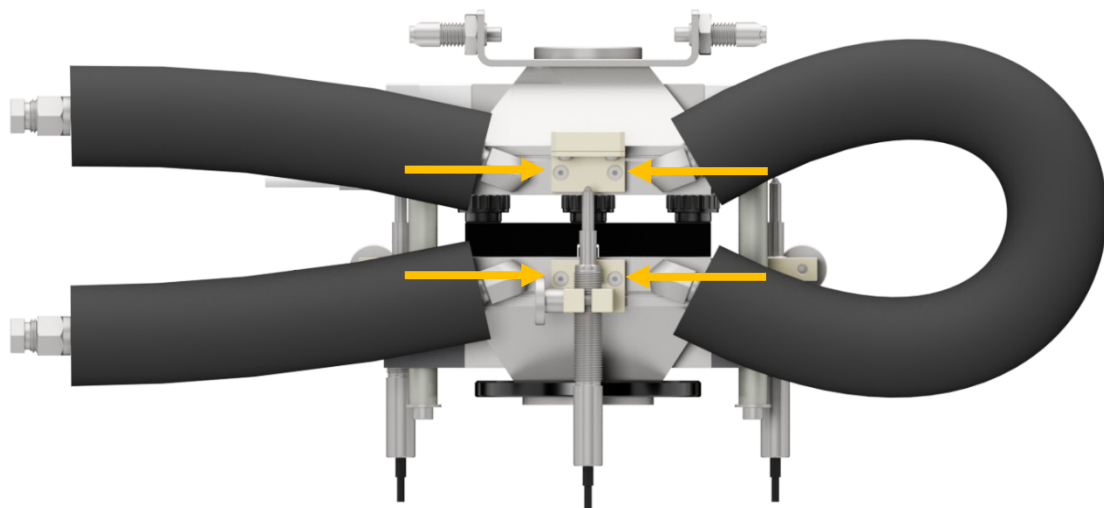

Figure 27

If you do connect fluid hoses in the CompreFrame, make sure they do not rotate the CompreCell Pouch in a way that causes collisions between CompreFrame and the Distance Add-On. Clamping the hoses in position with a laboratory stand can be helpful.

9.2.4 Sensor installation and handling

If you use sample stacks (pouch cells, potentially with foam pads, etc.) that are less than 9 mm thick, the sensors can be mounted permanently by following the steps below with an empty CompreCell Pouch.

If you use large sample stacks that are 9 mm or thicker, the sensors could be damaged when closing the CompreCell Pouch without a sample inside. Therefore, we recommend taking off the sensors every time you take the sample out of the CompreCell Pouch. Furthermore, the steps below need to be followed with the sample stack in the CompreCell Pouch.

Approach either the empty CompreCell Pouch or the CompreCell Pouch with your sample stack inside, set the force to a value between 150 N and 490 N and wait for the system to equilibrate. Ideally, set the temperature to 25 °C or your preferred standard value and wait for equilibration.

Connect the sensors to the Multi Data Sampler, connect the Multi Data Sampler to the computer, connect the 24V power supply and switch the device on.



Note: The connectors on the sensors are push-pull-connectors, which must only be pushed or pulled on the shrink wrapped part, not screwed or twisted!



Figure 28: Connect the sensors to the RHD Multi Data Sampler via the 4-pin LEMO connectors. Connect the Multi Data Sampler to the computer using RS-232 or USB via the adaptor, connect the 24V DC power supply and switch on.

Start the RHD.Distance.Server software, navigate to MDS-LVDT #0/Device Setup, select the appropriate COM device and click the connect button.

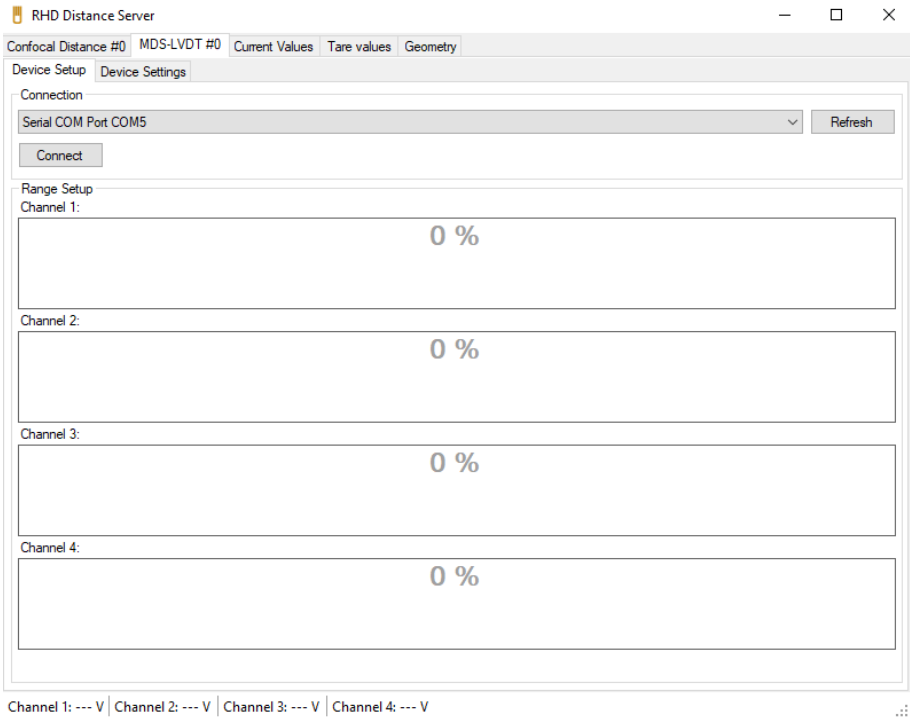

Figure 29: Start the RHD.Distance.Server application, navigate to the LVDT ribbon and select the appropriate COM device.

Insert the sensors into PEEK holders at the CompreCell IOS and push them up against the deflectors until they reach approximately 90% of the working range and clamp them in place by tightening the thumb screws.

	<p>WARNING: Do not exceed the working range of the sensor. Exceeding the working range may damage the sensor.</p>
--	--------------------------------------------------------------------------------------------------------------------------

	<p>ADVICE: Please note that a safe overload force is not defined. We recommend to monitor the sensor deflection on the computer during insertion.</p>
--	--------------------------------------------------------------------------------------------------------------------------------------------------------------

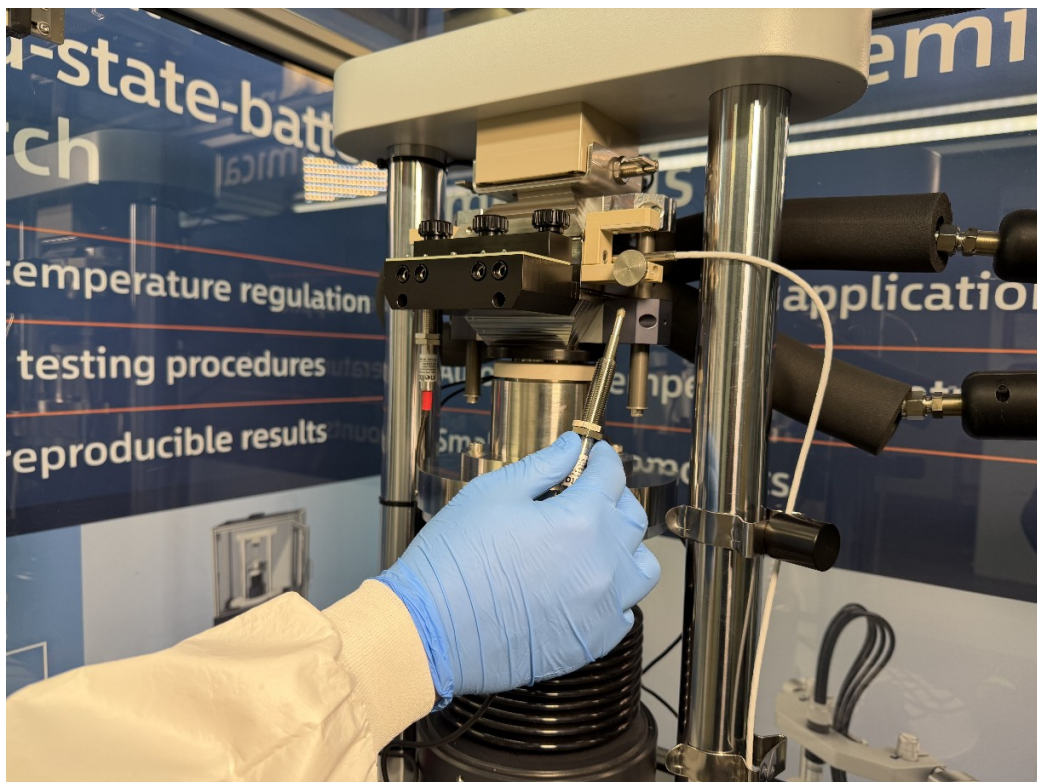

Figure 30: Insert the sensors into the PEEK holders and set the deflection to approx. 90%.



Figure 31: Fix the sensor in place by tightening the thumb screw. Do not overtighten.

Install the rear sensor in the same way.

Note: The rear sensor has to be inserted farther into the holder than the left and right sensor.

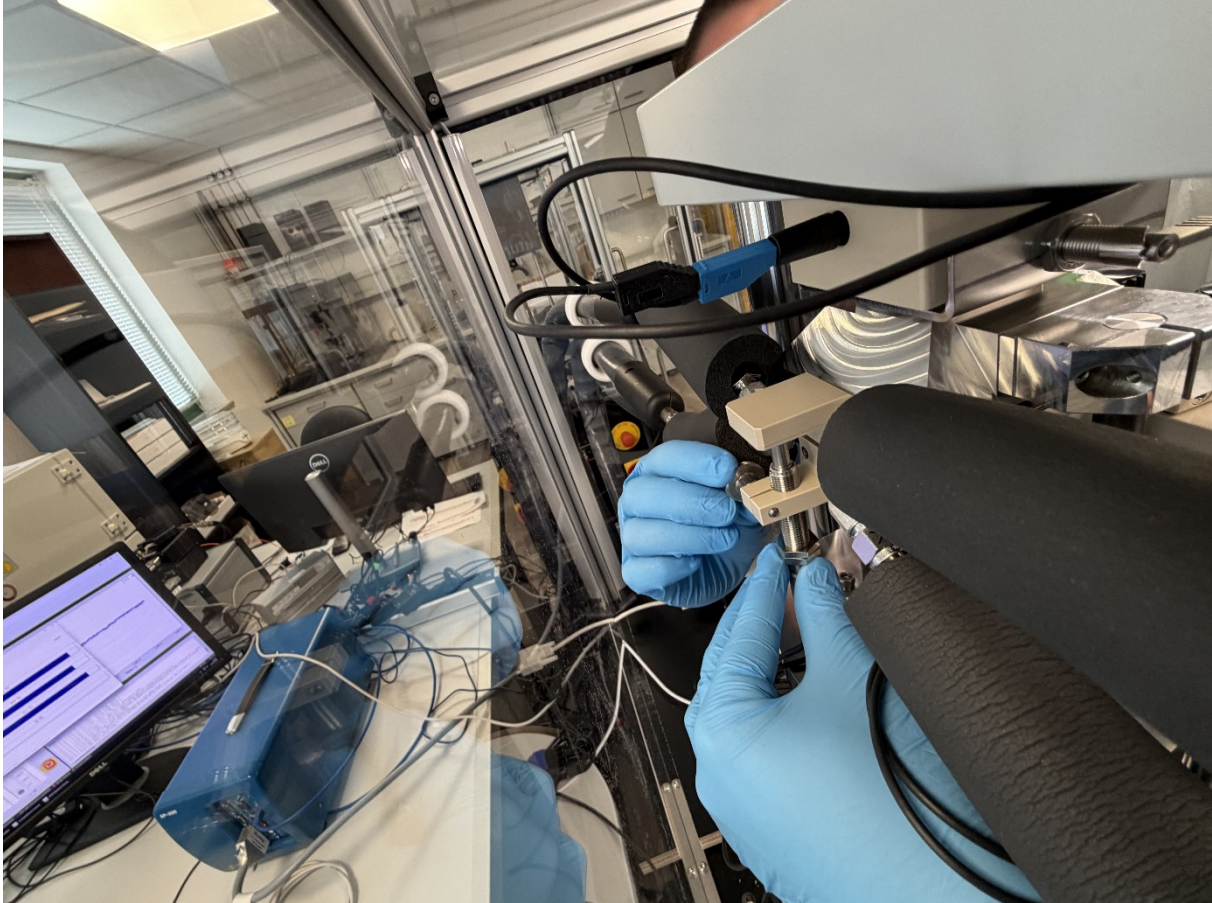

Figure 32: Reach around the pillars to insert and fasten the back sensor.

Before you start your measurement, or at any necessary point, you may navigate to the tare values ribbon and apply a tare value to the sensors.

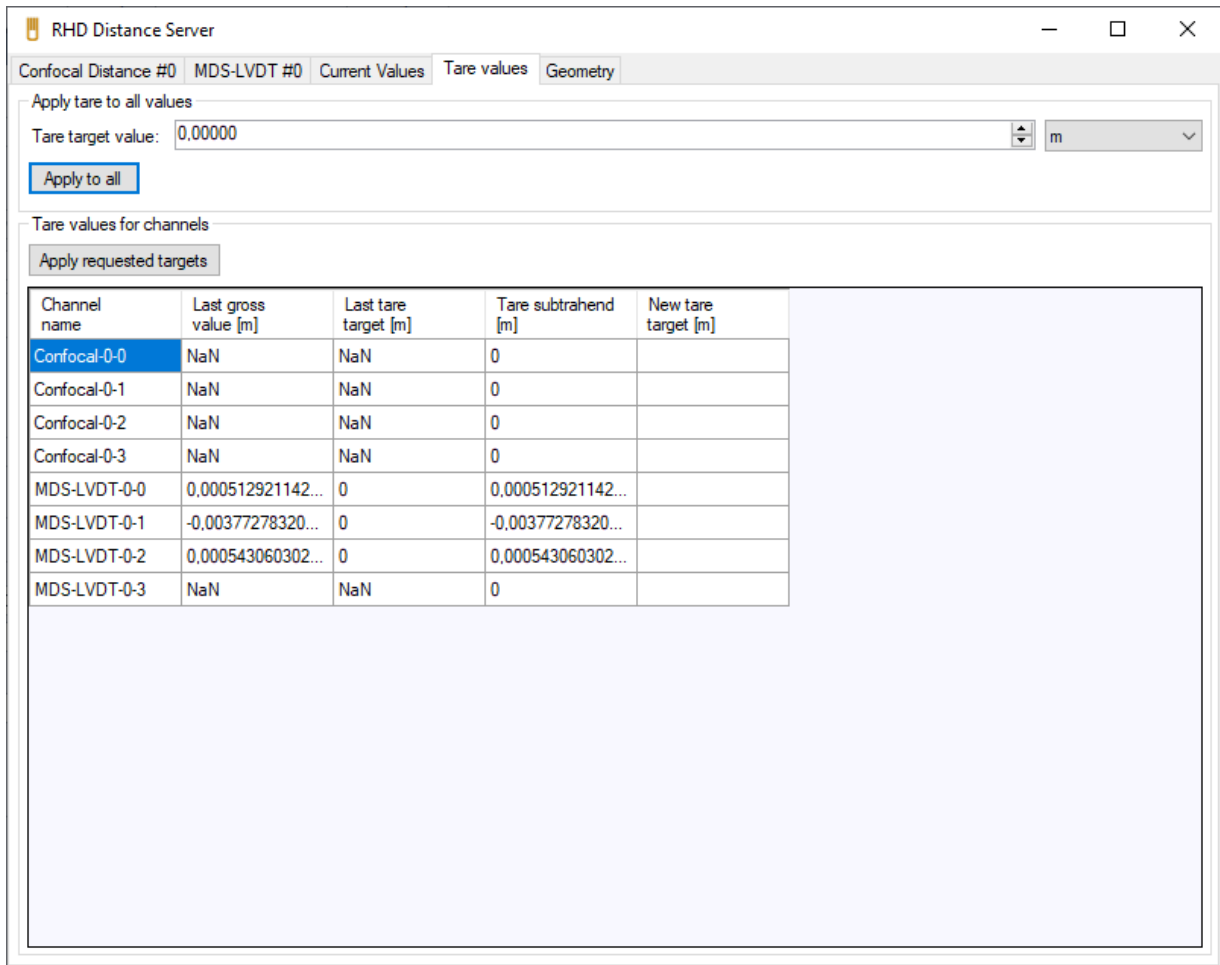

Figure 33: Current values and taring ribbon.

Switch to the geometry tab and select the **preset** for your version of the **CompreCell Pouch** in the top right corner (see label on the back of your CompreCell Pouch for identification and chapter 9.2.2 for an explanation of the differences). This will set the coordinates for the device you choose.

Select the **correct LVDT channel** for each vertex using the dropdown menus. Note that the vertex/channel assignment needs to be correct. In CompreCell pouch devices the sensor positions are not identical. Failure to select the right channels will introduce an error into the data.

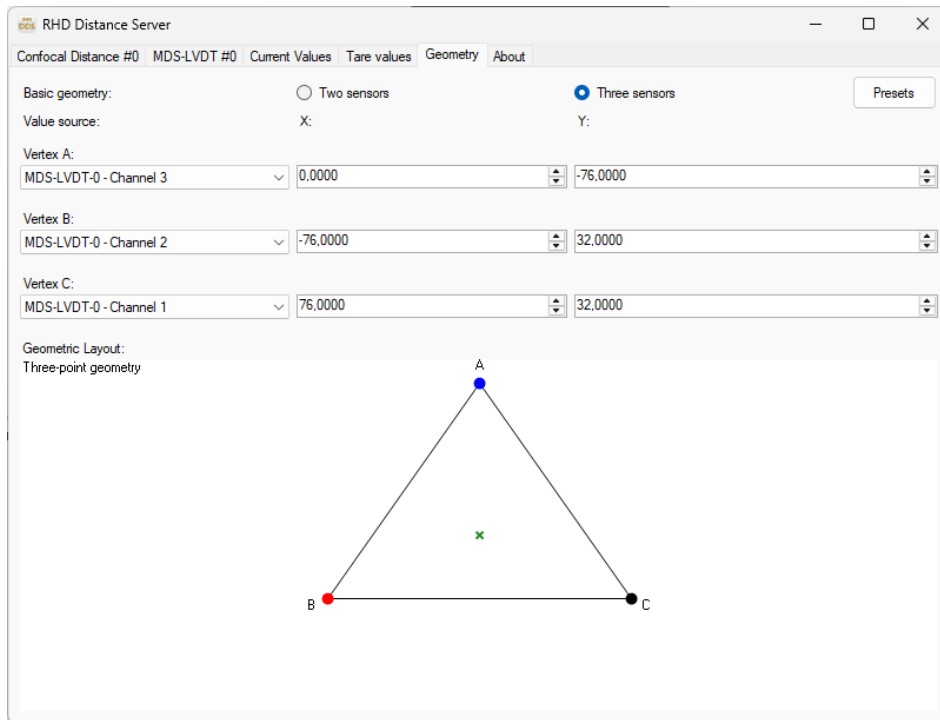

Figure 34: Geometry ribbon showing the settings for a CompreCell Pouch 10S. Note that in this case vertex A is assigned to the sensor at the rear side of the pouch cell holder, connected to channel 3.

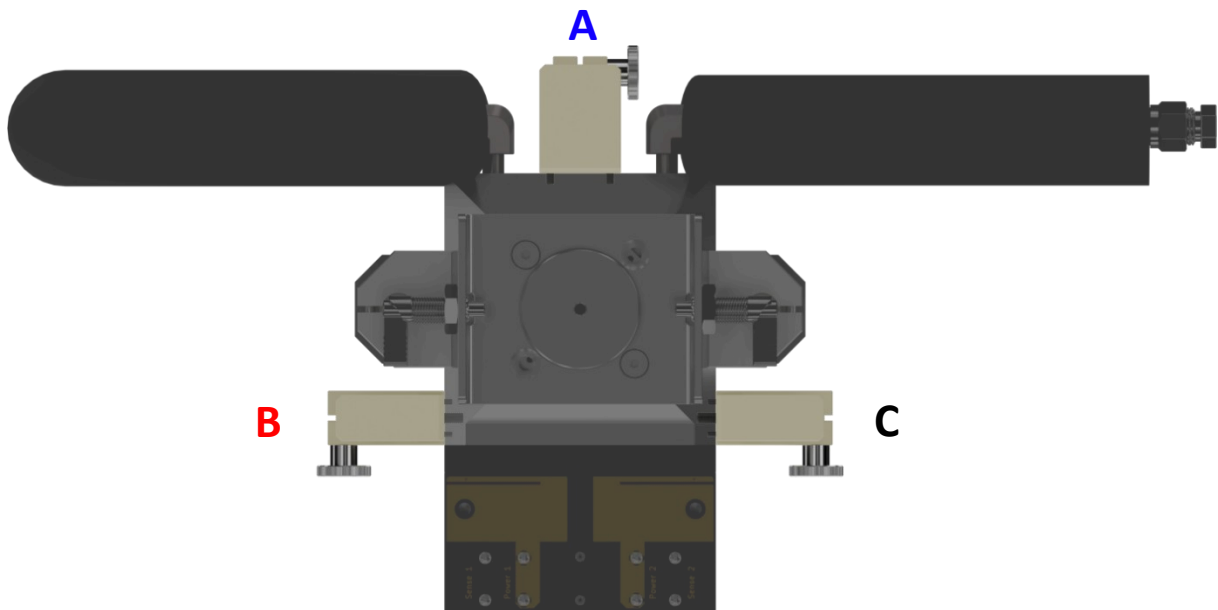

Figure 35: Sensors and corresponding vertices for CompreCell Pouch 10S HC
 For disassembly switch off the Multi Data Sampler, retract the CompreDrive and remove the sensors.

9.3 ComprePouch



CAUTION: Use the lever to open and close the ComprePouch. Handle the sensors with care, as they are susceptible to mechanical shock. When closing the ComprePouch with sensors installed, do not let go of the lever and close the device slowly.

9.3.1 Samples < 8.5 mm

Please refer to Initial software setup (chapter 8) if you are using the setup for the first time.

Connect two sensors to the Multi Data Sampler, connect the Multi Data Sampler to the computer, connect the 24V power supply and switch the device on.



Note: The connectors on the sensors are push-pull-connectors, which must only be pushed or pulled on the shrink wrapped part, not screwed or twisted!



Step 1: Connect the sensors to the RHD Multi Data Sampler via the 4-pin LEMO connectors. Connect the Multi Data Sampler to the computer using RS-232 or USB via the adaptor, connect the 24V DC power supply and switch on.

Start the RHD Distance server software, navigate to MDS-LVDT #0/Device Setup, select the appropriate COM device and click the connect button. Navigate to the device settings tab, disable unused channels and make sure the used channels are set to 0-10V.

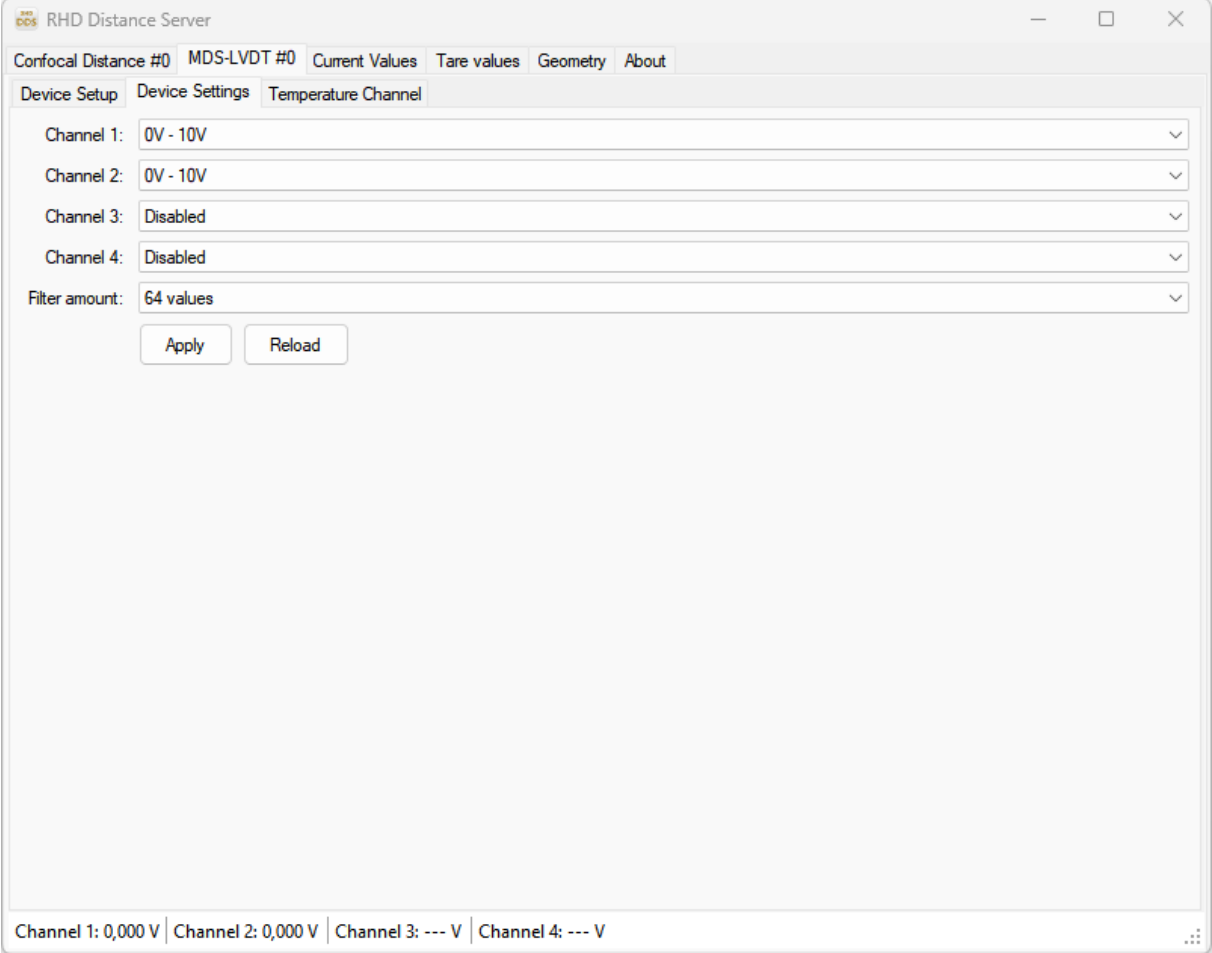



Figure 36: Unused channels can be disabled in the device settings tab.

Make sure there is a hexagonal nut screwed onto the sensor. Place the insertion sleeve on a flat surface as shown in Figure 37 to Figure 39 and insert the sensor into the insertion sleeve. Screw the sleeve onto the sensor, while keeping contact with the surface. Monitor the sensor signal on the computer during this process and adjust the deflection value to 90-95%.

	<p>CAUTION: Make sure that the working range of the sensors is not exceeded at any time.</p>
-------------------------------------------------------------------------------------	-----------------------------------------------------------------------------------------------------

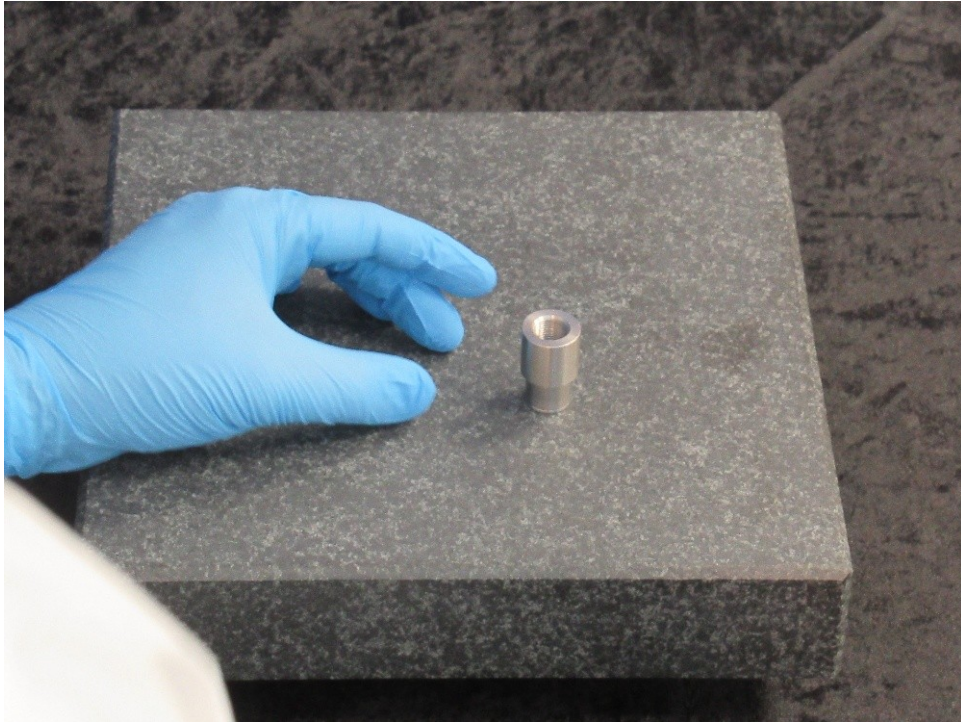

Figure 37: Place the insertion sleeve on a flat surface.



Figure 38: Insert the sensor and screw the nut onto the sensor while keeping contact with the surface.

Make sure not to exceed the working range of the sensor at any time. The deflection value you adjust here limits the working range available for an experiment.

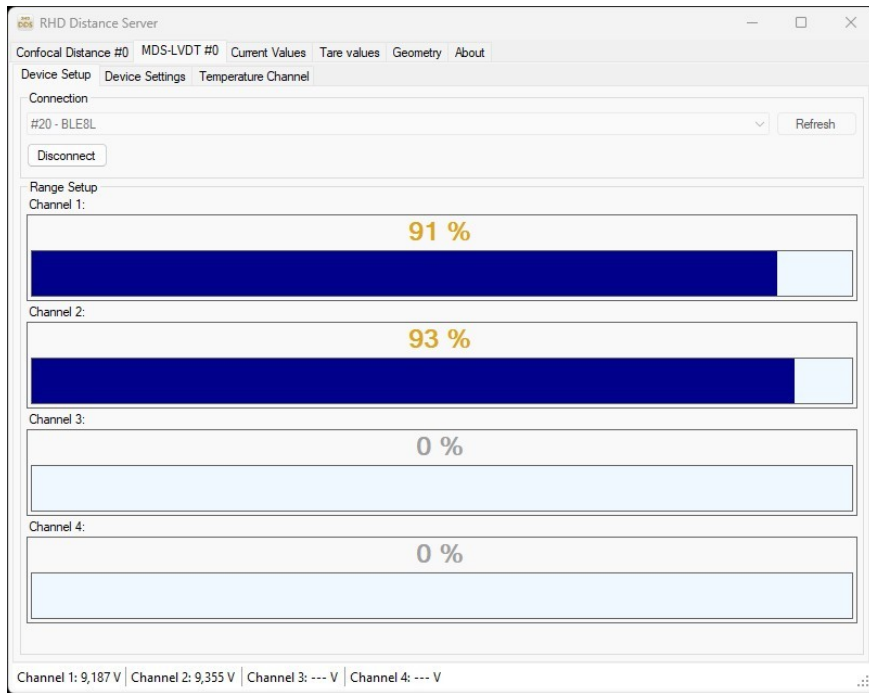

Figure 39: Adjust the sensors to 90-95%. Monitor the channels and make sure that the working range is not exceeded.

Fix the sensor position by fastening the hexagonal nut onto the insertion sleeve. Make sure to fasten the sensor securely, but use only your hands to avoid applying excessive torque. Tightening the hexagonal nut enough is especially important when you plan to temperature cycle the setup as the thermal expansion and contraction could lead to a loose sensor otherwise.

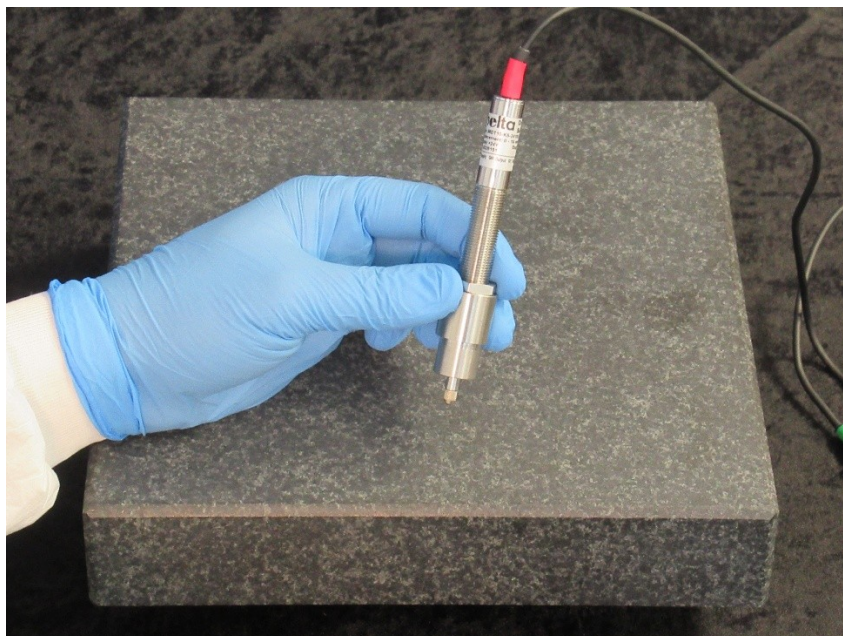

Figure 40: Sensor with fastened hexagonal nut.

Open the ComprePouch and insert the sensors into the holes at both sides of the ComprePouch.

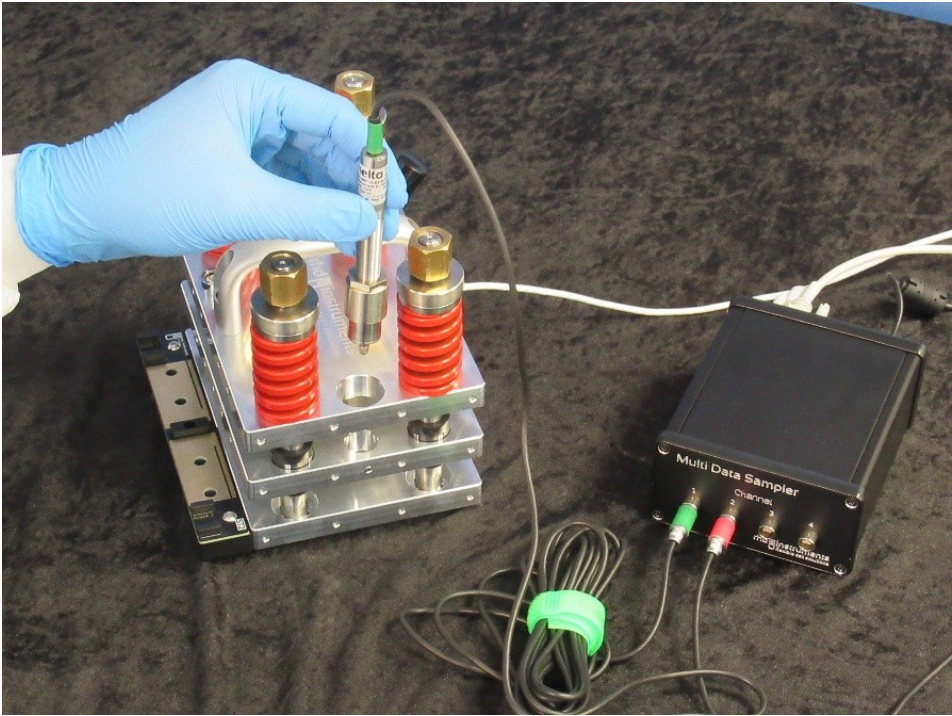

Figure 41: Inserting the sensors.

Fix the sensors in place by tightening the set screws, using the 2 mm hex screw driver.

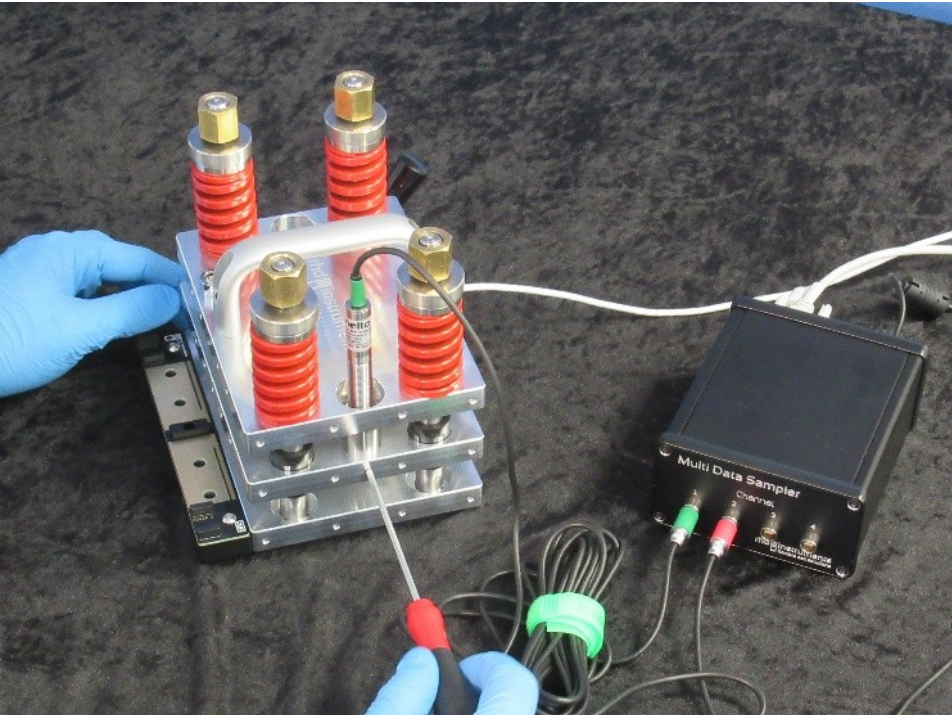

Figure 42: Tightening the screws.

Open the distance server software. Navigate to the geometry ribbon and configure a linear configuration as follows: Select the **ComprePouch** preset and choose the **LVDT** channels for Vertex A and B that correspond to the ports where the sensors are connected. As left and right are not defined, it does not matter which of the two channels you select for which vertex.

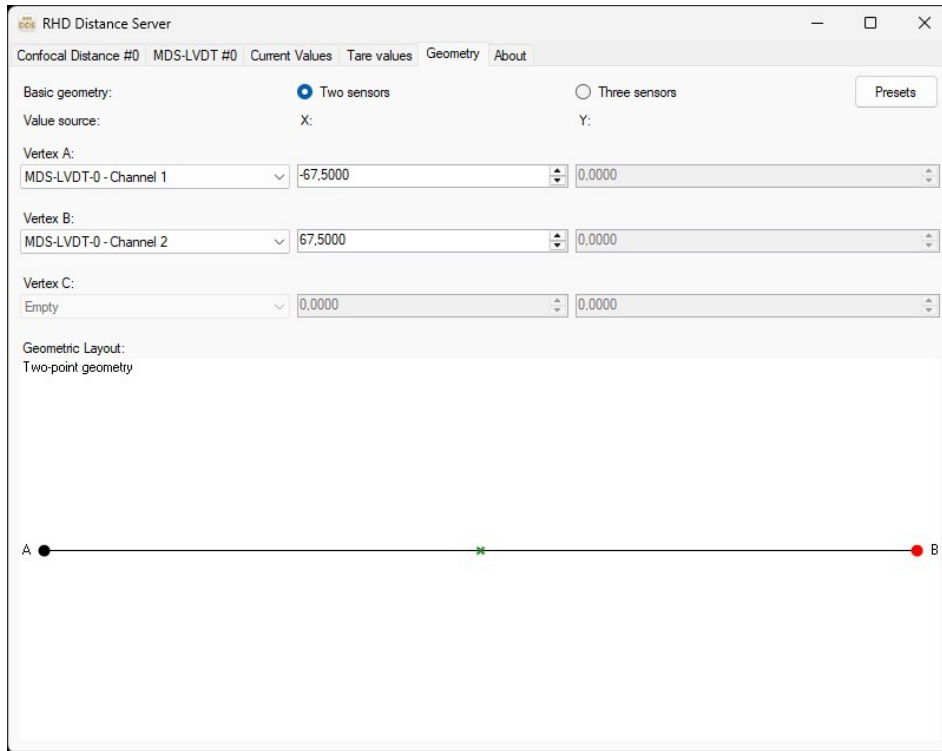

Figure 43: Set up the sensor geometry in the geometry ribbon. Use presets for ComprePouch.

	<p>CAUTION: Ensure that the set screws used for fixating the insertion sleeves do not protrude beyond the surface of the plate before closing the ComprePouch. Failure to do so might cause permanent damage to the ComprePouch setup.</p>
--	---------------------------------------------------------------------------------------------------------------------------------------------------------------------------------------------------------------------------------------------------

Close the ComprePouch and adjust the applied force to a value of choice and tare the sensors.

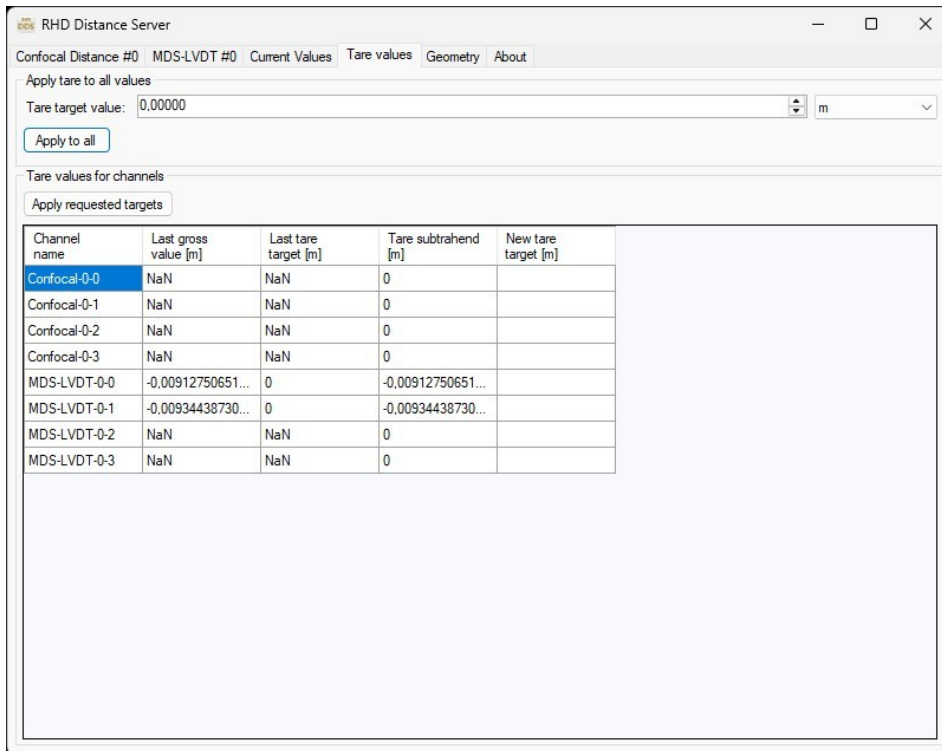

Figure 44: Tare the sensors with the ComprePouch closed.

Release the applied force, open the ComprePouch and insert your cell. We recommend to run measurements at constant temperature. Insert the cell and set the force to the value chosen before.

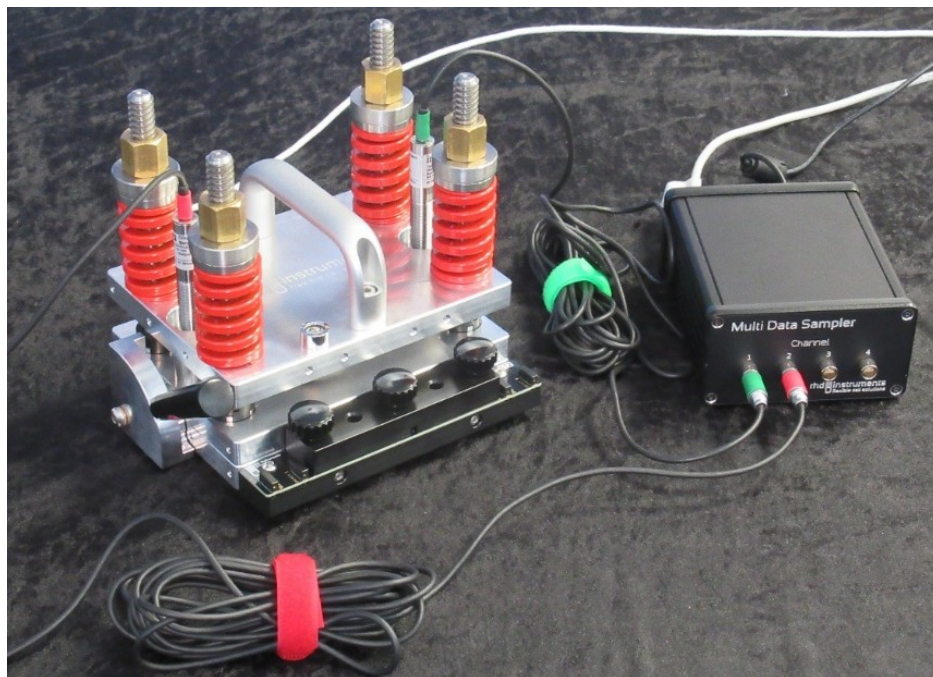

Figure 13: Fully assembled ComprePouch Setup.

9.3.2 Large samples > 8.5 mm

If you have a very large cell, it can be necessary to adapt the sensor positioning to stay within the working range.



CAUTION: Closing the empty ComprePouch without the respective sample, while the sensors are positioned in any other way than described in chapter 9.3.1 is unsafe and might lead to permanent damage to the sensors.

After performing the setup as described in chapter 9.3.1, follow the instructions below.

- » Place the sample in the ComprePouch.
- » Remove the LVDT from the ComprePouch and loosen the hexagonal nut.
- » Rotate the insertion sleeve into a higher position relative to the sensor.
- » Retighten the hexagonal nut.
- » Put the LVDT sensor back into the ComprePouch and secure it. Check if it is within working range. **Note that removing the sample and closing the ComprePouch is not safe with the sensors mounted like this!**
- » Tare the sensors.
- » You can start your relative measurements now.

10 Usage

In this chapter we want to give some comments on using the distance add-on with the different cell types. This section provides some starting points for your experiments and explains caveats of distance measurements.

10.1 System warm-up

Because the LVDT sensors warm up slightly after being powered on, we recommend allowing the system to stabilize for approximately 30 minutes before taring the sensors or performing any critical measurements.

10.2 Absolute vs. relative measurements

For CompreCell Pouch and ComprePouch setups, it is possible to close the empty cell-holder and tare the device at a given force and temperature setpoint, thus enabling absolute measurements.

With the cylindrical CompreCell setup absolute measurements cannot be achieved directly. However, it is possible to determine your sample height in 2 ways:

- Before you start your experiment (recommended):
sample height = filled cell height - empty cell height
Both of those values can be measured with a height gauge
- After your experiment:
measure the sample pellet with a micrometre screw gauge
We recommend to use this value to cross check your measurements.

10.3 Calibrating force + temperature changes

Force and temperature changes cause contribution of the cell in use to your distance measurements, which can amount to several micrometres per kN or °C.

Precise temperature control is essential for any measurement that targets micrometre accuracy or better. The two most important factors for this are changes in material dimensions and sensor drift due to temperature changes.

Note that due to hysteresis between the pressure increase and decrease sweeps, it's important to follow the same pressure procedure for the sample as for the blank measurement and perform the correction for the corresponding values.

To obtain a calibration curve we recommend to subject the empty cell that is designated for the experiment to the force and temperature procedure that you want to use for the sample. After the measurement, the calibration can be subtracted to obtain the sample signal.

For cylindrical CompreCell setups the standard operating procedure looks like this:

- Calibration curve with empty cell:
 - Assemble your CompreCell
 - Measure the empty of this filled CompreCell
 - Mount the Distance Addon
 - Execute your pressure + temperature procedure
- Measurements with sample:
 - Prepare the CompreCell with a sample inside
 - Measure the height of this filled CompreCell
 - Mount the Distance Addon
 - Tare the sensors to your cell height
 - Execute your pressure + temperature procedure (with the filled cell)
 - Disassemble the CompreCell
 - Measure your sample pellet (if possible)
 - Subtract the values measured with the empty cell from the values measured with the filled cell
 - Cross check your Distance Addon measurements with the sample pellet thickness (measured with a micrometre after the experiment)

10.4 Constant distance mode in CompreDriveControl

The LVDT Distance Addon can be used in conjunction with a CompreDrive system to operate in the constant distance mode. In this mode, the target value is switched from force to distance. After starting the constant distance mode at a given force setpoint, the CompreDrive will keep the sensor distance constant, e.g. by increasing the applied force, if a cell expands e.g. during a charge cycle. This mode is particularly helpful if the possible force evolution of a cell needs to be characterized. Note that you need to configure the MDS center distance data stream as a distance provider.

For instructions how to use the constant distance mode refer to chapter 8.4 in the CompreDriveControl user manual.

11 Troubleshooting

11.1 No data connection to the Multi Data Sampler

- Ensure that the device is correctly connected to a serial port on the PC or the serial adaptor provided with the device and switched on.
- Make sure that the serial port is not blocked by another application. Restart the PC and try to connect the device before starting any other application.
- If you are using an LVDT setup, make sure that you are not trying to connect via the confocal tab.
- If you are using a serial to USB adaptor supplied by rhd instruments make sure that the FTDI device driver is installed.

11.2 Invalid sensor readings

- Check the connection cable of your sensors for damage.
- Verify that the sensors are connected to the intended channels.
- Check that the selected voltage range is compatible with the sensor.
- Make sure that the sensors travel freely over their entire measuring range without any signs of binding.

11.3 High noise on the signal

- Check the connection cable of your sensor for damage.
- Ensure that the noise is not just a visual issue. Nominal noise level of the MDS is on the order of a few hundred microvolts.
- Make sure that the sensors travel freely over their entire measuring range without any signs of binding.

11.4 Sensor data is not transferred to CompreDriveControl

- Ensure that the version of CompreDriveControl is 1.17 or higher. Ensure that the RHD.Distance.Server version is 1.0.10 or higher.
- In CompreDriveControl close and re-open the Manual Control Plots window to refresh displayed data streams.
- The Center Distance value is only shown if the geometry settings in the RHD.Distance.Server are fully configured. Make sure that the channels selected for the individual vertices are activated.

12 Settlement

Warranty will be granted for a period of 2 years starting at the date of delivery.

Explicitly left out from warranty are parts that are subject to premature wear and tear due to use or other natural wear and tear. These components are regarded as consumables. Damage on the optical cable is excluded from warranty.

The costs for sending repaired or exchanged goods to the customer will be paid for by rhd instruments.

rhd instruments has to be notified of apparent defects and damages which occurred during production or delivery within 14 days after receiving the delivery. If a notification of apparent defects and damages does not occur within this period of time, the goods shall be deemed to have been accepted; as a result, the order will be assumed to be completed and approved.

Please note: Only workshops authorized by rhd instruments are allowed to perform repairs on the devices. If any mechanical or electronic components of the products are altered by customers themselves or by unauthorized workshops, a claim for warranty against rhd instruments is forfeited.

In case of a claim or sending back goods for repairs to be performed, please ask for the decontamination form beforehand. In general, rhd instruments must be contacted via e-mail or phone prior to any shipping of damaged goods.

13 Contact and Technical Support

For any questions with regard to our products, orders, or request for repairs please contact rhd instruments:

info@rhd-instruments.de

Phone: +49 6151 8707187

Fax: +49 6151 8707189

Web: <http://www.rhd-instruments.com>

rhd instruments GmbH & Co. KG

Otto-Hesse-Straße 19 / T3

64293 Darmstadt

Germany

Sitz der Gesellschaft: Darmstadt

Amtsgericht Darmstadt HRA 85824

WEEE-Reg.-Nr. DE 54715752

Haftende Gesellschafterin: rhd instruments Verwaltungs GmbH

(Sitz: Darmstadt, Amtsgericht Darmstadt HRB 96374)

Geschäftsführer: Dr. Benedikt Huber und Dr. Marcel Drüschler