

Microcell HC User Manual

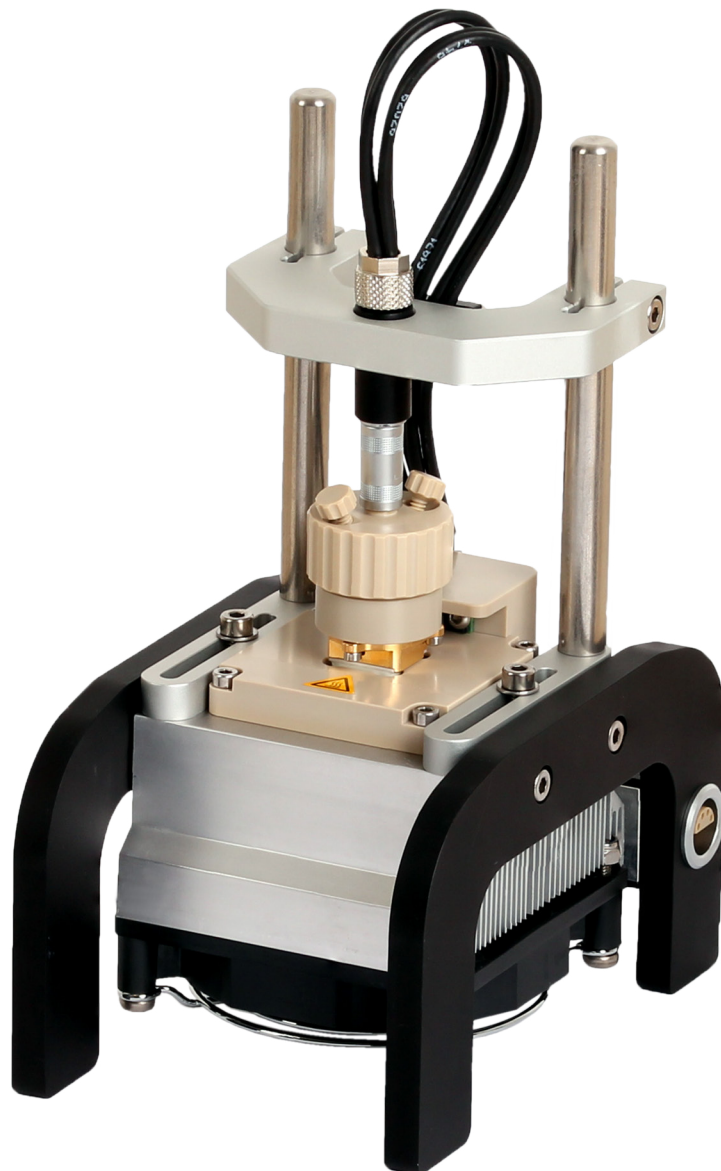

Version 2.3 EN



Content



General information	5
Important general safety notes	6
Components of a Microcell HC	8
Operation conditions, storage and rated values	11
Product description	12
Essential features at a glance	12
Quick installation of the Microcell HC Setup	13
rhd adapter boxes	14
Settlement	16
Contact and Technical Support	17
EC Declaration of conformity	18

General information

Thank you for your confidence in our products and services. We wish you pleasure and success with your new Microcell HC measuring system. The Microcell HC measuring system has especially been developed for professional electrochemical material characterization.

- » **Please read these instructions carefully before using the device for the first time. It includes everything you need to know to avoid physical injuries and damages.**
- » **Please pay attention to all safety notes in this instruction manual.**
- » **Please keep this manual safe. In case of selling or leaving the device to third parties, please do not forget to hand this manual over as well.**
- » **The operation of the Microcell HC setup should only be performed by properly trained and experienced members of staff.**
- » **The setup has been designed only for electrochemical measurements under temperature- and potential-controlled conditions. This setup should not be used for any other purposes.**
- » **To avoid unstable operating conditions, the Microcell HC setup and the individual components should not be used if**
 - **they are not free of noticeable damages,**
 - **they were stored or operated under unapproved conditions (see Operational conditions, storage and rated values),**
 - **they were exposed to high mechanical stress exceeding normal usage for a prolonged period of time,**
 - **they were altered by members of staff not authorized by rhd instruments.**
- » The instructions in this manual were carefully checked for correctness; however, liability for any mistakes in form and content will not be assumed. Additionally, rhd instruments GmbH & Co. KG (in the following rhd instruments) reserves the right to change the setup and design of the products presented and described within this manual. Such changes are necessary to guarantee the continuous development of the products and thus the improvement of product quality and reliability.
- » Markings in this manual

Marking	Meaning
	Indicates the handling and consequences of safety notes.
 WARNING	Indicates a hazardous situation, which, if not avoided, could result in a serious injury or death.

 CAUTION	<p>Indicates a hazardous situation, which, if not avoided, may result in minor or moderate injury.</p>
 ADVICE	<p>Indicates potential physical damages and other important information in connection with your device.</p>

Important general safety notes



WARNING: Danger of electric shock, fire through short-circuit

A short circuit could be caused by defect cables and by humidity or moisture. A short circuit can warm up the conductors, so that the insulation will melt which could lead to fire.

- » Please just use the original cables, which are included in delivery. They are aligned for your device and guarantee the necessary safety for you and your device.
- » Do not operate the device with wet hands.
- » Operate the device only in dry rooms.
- » Do not operate the device outdoors.
- » Please only follow the instruction manual for cleaning your device.
- » Make sure that cables and conductors will not be damaged. Damages could be caused by heat impact, chemical influence or mechanical impacts as rubbing, bending, tearing or rolling over.
- » Prevent your device from falling-off. In case of falling-off, please inform rhd instruments or a electrician authorized by rhd instruments before switching it on again.
- » If your device should be damaged or defect: Disconnect the power supply by pulling out the power cord. Never operate your device with damaged housing. Do not open the device. Never repair the device on your own. The device should only be repaired by either rhd instruments or by an electrician authorized by rhd instruments.
- » Please follow this instruction manual for maintaining your device.
- » Please just use original spare parts delivered by rhd instruments.



WARNING: Danger of burning on hot parts

Measuring cells connected to the Microcell HC system can be set to temperatures ranging from -40°C up to +100 °C.

- » Do not touch the accessible metal parts of the measuring cell during operation, especially during heating or cooling steps.



ADVICE: Connect and unplug any cable connection carefully.

- » The Microcell HC cell stand is connected to the temperature controller via a 8-pole cable having two 8-pole LEMO connectors (controller cable). There is only one possible configuration to establish the connection. Thus, do not apply any excessive force.
- » The measuring cells are connected by a 4-wire LEMO to BNC cable (cell cable). Also in this case, there is just one possible configuration for establishing the connection. Do not apply any excessive force. In case of physically disconnecting the measuring cell, please note that you have to pull down the outer casing of the LEMO plug situated at the cell's cap simultaneously while slightly removing the cable to unlock the connection. **As it is a push-pull connector you must not twist it!**

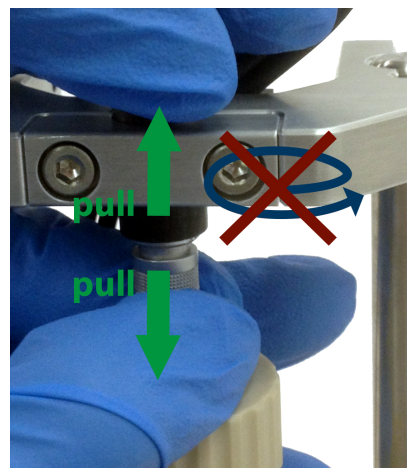

ADVICE: Handle chemicals with care.

- » When handling chemicals during preparation and performance of measurements with the Microcell HC, the usual safety advice in accordance with the H, EUH, and P statements (in the European Union: rating principles according to the CLP regulation) and appropriate safety measures have to be observed. This also applies to subsequent cleaning and decontamination.



ADVICE: Sufficient cleaning increases lifetime of your system.

- » After using Microcell HC for electrochemical measurements, all components in contact with chemicals have to be thoroughly cleaned. Insufficient cleaning, decontamination, and drying of the components of Microcell HC can result in damage due to corrosion and thus possibly in falsification of the measurement results.



ADVICE: Be careful when bringing chemicals in contact with parts of your system.

- » When operating your Microcell HC system with compatible measuring cells please be advised to only use samples that are chemically inert towards the main ingredients of the measuring cell (e.g., platinum, polyether ether ketone (PEEK) and soda-lime glass). Caution: Fluorine-containing electrolytes can release hydrofluoric acid (HF) when decomposing. In general, the Microcell HC system is only allowed to be operated under conditions that correspond to the specifications described in this manual and under which the main components of the measuring cell used are stable.

Components of a Microcell HC

» Please unpack your device carefully.



ADVICE: If your items have been shipped in a tool case, keep the case for future storage and transportation.

» Please check if the delivery is complete:

- 1 x Temperature controller (Eurotherm 3216)
- 1 x IEC cord (power cord with a suitable power plug for the locality in which the appliance is used on one end and a C13 connector on the other)
- 1 x 3 m 9-pin D-sub cable 1:1, male connector on one end and female on the other
- 1 x 1 m Controller connection cable type 8-pole LEMO to 8-pole LEMO
- 1 x Microcell HC cell stand
- 1 x Positioning unit containing micrometer screw (ONLY Item No. 840102; NOT included in item no. 840101)
- 1 x Cell connection cable type 4-pole LEMO to 4 x BNC (separate)
- 1 x 10 g heat sink compound
- 1 x manual „Microcell HC“ and 1 x manual „Measuring Cells“ (both printed)
- 1 x Adapter Box 4 x BNC to 4 x banana + 3 x BNC-cable (30 cm each, male-male)
- 1 x USB to RS232 converter
- 1 x hexagon key 1.5 mm
- 1 x hexagon key 3.0 mm

» Please check if the delivered items are undamaged.



ADVICE: If the delivered items should be incomplete or damaged please contact us either via e-mail or via our hotline.

In case accessories of other manufacturers are used, rhd instruments will accept no liability.

Microcell HC cell stand

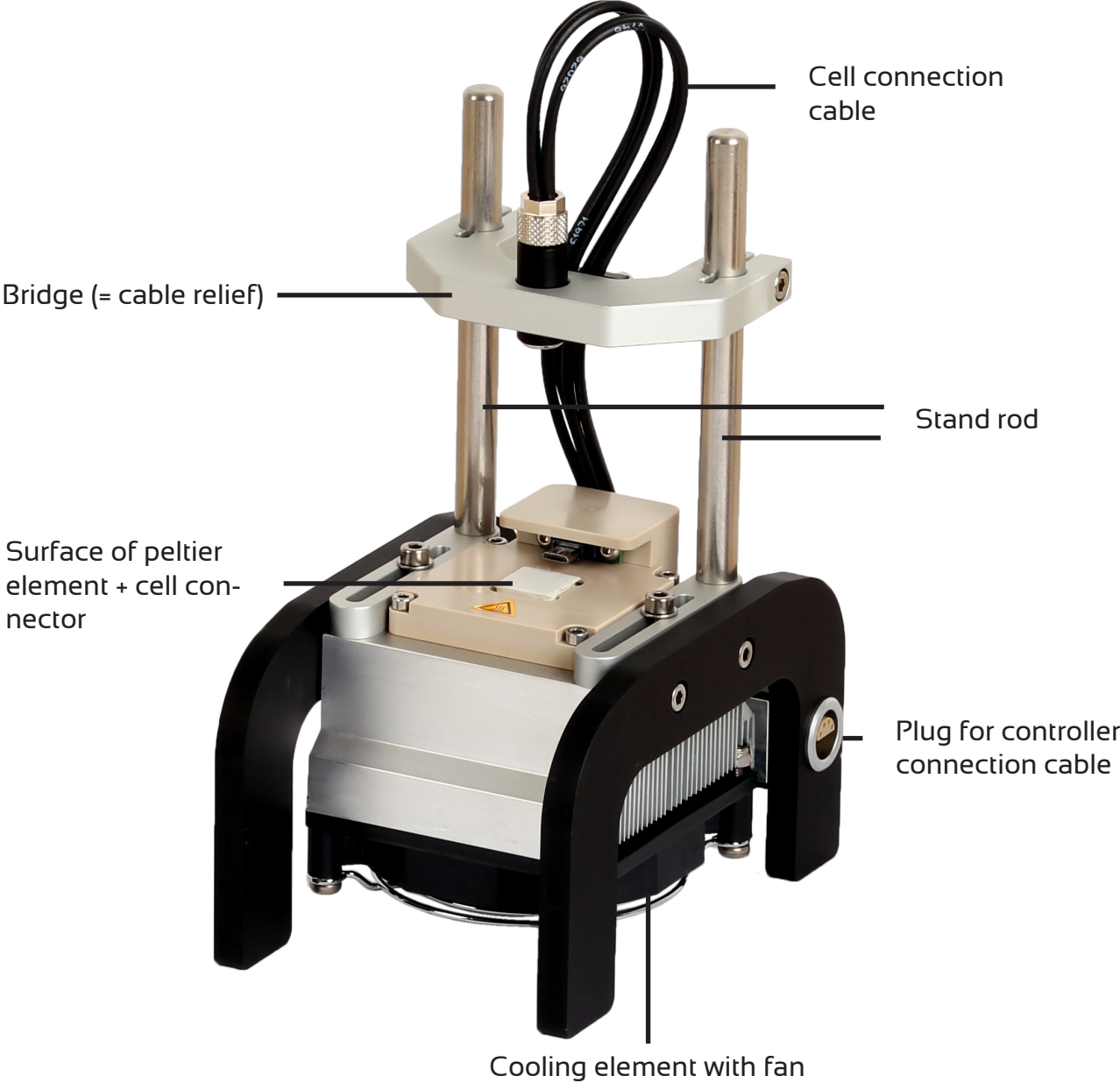

Positioning unit

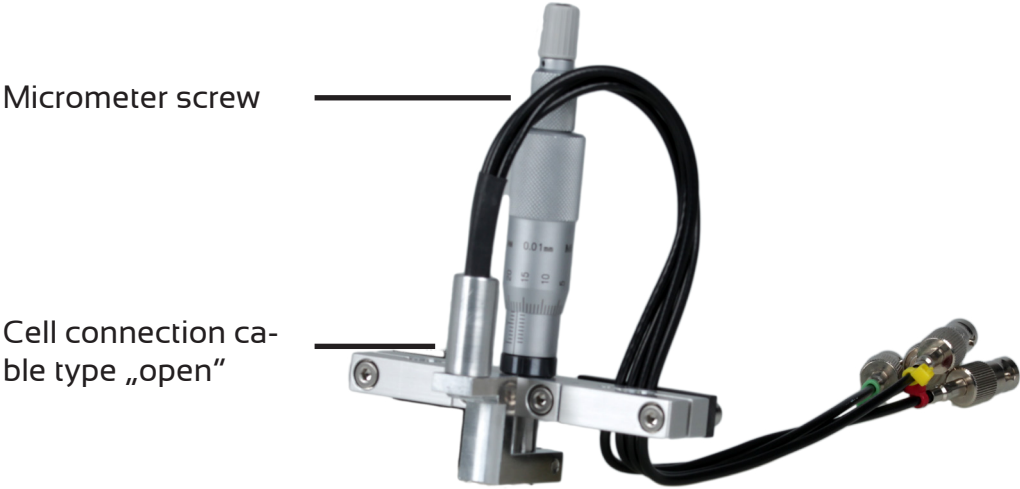

Temperature Controller (3216)

Front panel

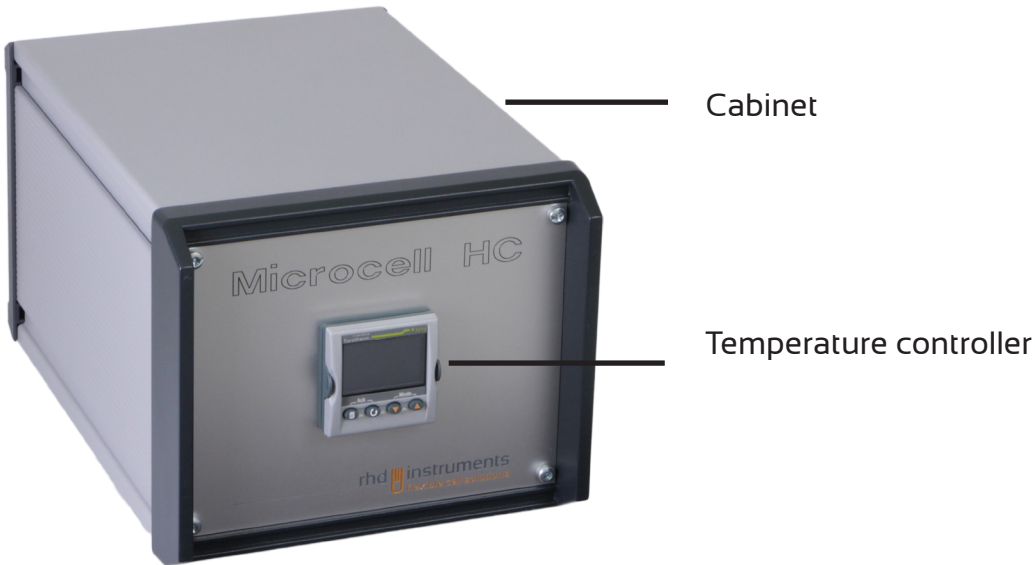

Back panel

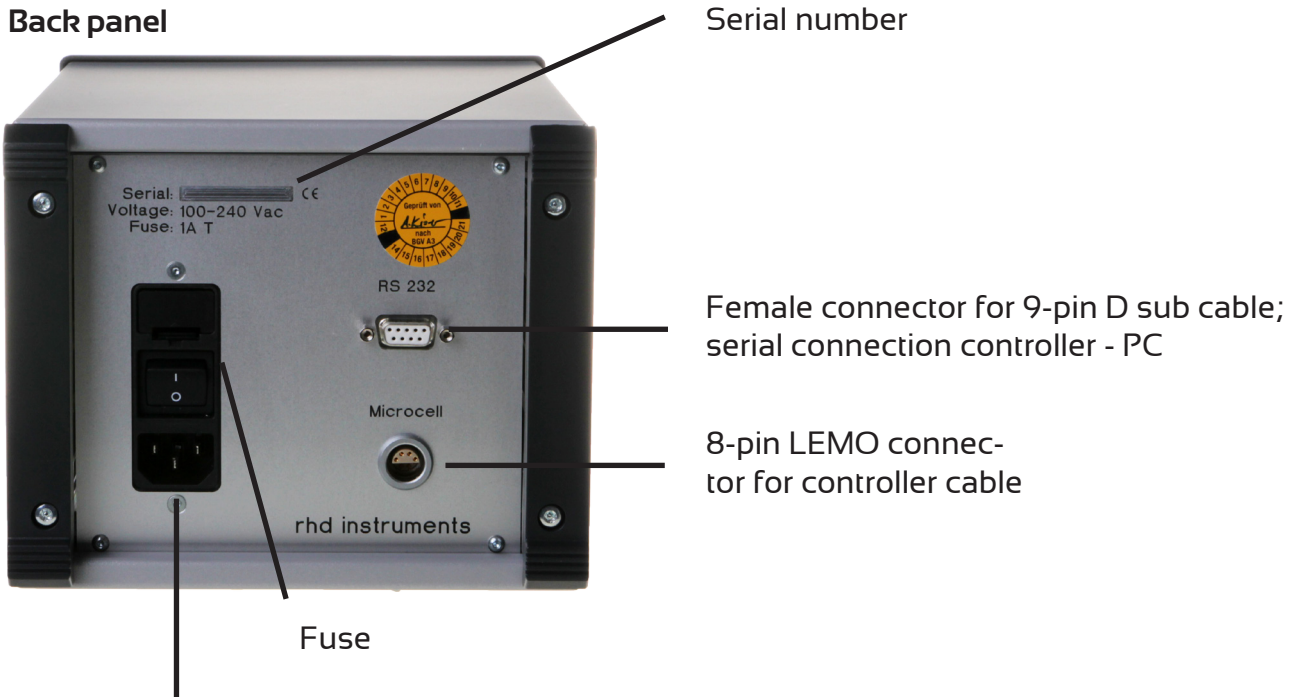

Power socket + jack

Control panel

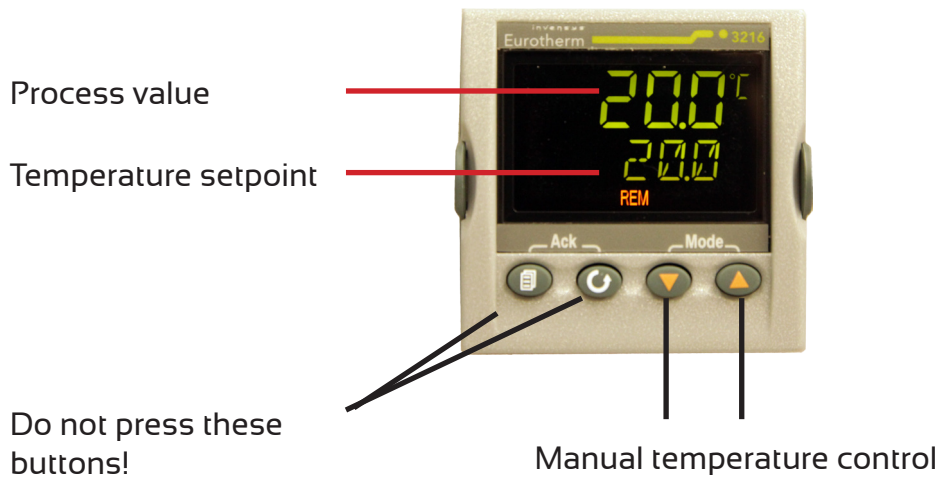

Operation conditions, storage and rated values

» Mains voltage for thermostat:	$U_{AC(rms)} = 100 \text{ to } 240 \text{ V}$
» Temperature range during operation (measuring cells):	$T_{operation} = -40 \text{ °C to } +100 \text{ °C}$
» Temperature range during operation (environment):	$T_{env., operation} = +10 \text{ °C to } +40 \text{ °C}$
» Temperature range during storage:	$T_{storage} = +10 \text{ °C to } +30 \text{ °C}$
» Relative humidity (RH) for working and storage area:	(non-condensing) 0 to 90% RH
» Atmosphere during storage:	non-corrosive
» Maximum electrode potential:	$U_{DC,max} = \pm 30 \text{ V}, U_{AC(rms)} = \pm 30 \text{ V}$
» Maximum operational pressure for sealed measuring cell:	$p_{max} = 5 \text{ bar}$
» Rated values of the thermostat:	27 cm x 18.5 cm x 16 cm (L x W x H)
» Rated values of the cell stand:	20 cm x 20 cm x 25 cm (L x W x H)
» Total weight (controller, cell stand, cables):	5 kg

Product description

The Microcell HC setup is suitable for the **electrochemical characterization** of liquids, gels, and polymers as well as solid samples and heterogeneous systems. Depending on the measuring cell, the measurements can be performed in both a two- and three-electrode setup, during which the temperature of the sample can be quickly and precisely controlled. Only a small sample volume (milligram range) is required, which allows for electrochemical analyses of substances that are only available in small amounts and/or extremely expensive.

Already **established applications** of the setup are the measurement of the **conductivity** of ionic liquids, polyelectrolytes, and polymer electrolytes, electrochemical impedance spectroscopy for the characterization of the **interface** ionic liquid/electrode, cyclic voltammetry for a large variety of electrochemical systems (e.g. dyes solved in organic solvents), and charge/discharge experiments on **Li-ion battery** systems.

Especially cyclic voltammetry experiments, but also in general measurements utilizing a three-electrode setup, require a **reference electrode**. If it is not planned to use a specially fitted quasi- or pseudo reference electrode, the small sample volumes represent a challenge as commercially available reference electrodes are too large and thus not suitable. For electrochemical measurements of ionic liquids, a micro-reference electrode developed by rhd instruments can be used. We will further advance the development of the micro-reference based on the specific requirements of our customers. For measurements of battery electrolytes, a clamp mounting is available, which allows the usage of a lithium reference electrode.

Essential features at a glance

- » Large temperature range between -40 °C and +100 °C; possible limitations to the range depend on the measuring cell used and measuring conditions
- » Quick temperature control with maximum temperature ramping rate from 10 °C/min to 60 °C/min depending on the measuring cell used
- » Precise temperature control of the measuring cell with a tolerance of ± 0.1 °C
- » Measurement of volatile samples when using a sealed measuring cell
- » Small sample volume, varying with the design of the measuring cell
- » Fast and comfortable assembly
- » Quick exchange of the reference electrodes
- » Measurements possible outside or inside a glove box
- » Compatible with a large number of electrochemical measuring instruments of various manufactures (among them, but not conclusive, Novocontrol, BioLogic, Ivium, Ametek, Zahner, **Metrohm Autolab**)

Note:

If you have questions, for example with regard to the compatibility of your measurement devices, do not hesitate to contact us (see Contact and technical support).

Quick installation of the Microcell HC Setup

- » Fix both stand rods. Use the screws (M4 hex bolt AF 3 mm; fixed to the cooling block by default factory configuration) and tool included in the package.
- » Slide the bridge along the stand rods. Adjust the final height to allow for sufficient space to connect the measuring cell. You will have to adapt the height whenever switching to another measuring cell type (e.g. from *TSC 1600* closed to *TSC battery*). Tighten the screws for fixing the position.
- » Make sure that the position of the bridge has been optimized for the setup you want to use. In case of Microcell HC setups of type „closed“ the hole in the bridge (cable relief) has to be above the upper electrode connector of the measuring cell's cap. In case of Microcell HC setups of type „open“ the connector for fixing the upper electrode should be above the lower electrode or sample mount.
- » Connect the controller cable (8-pin LEMO) to the cell stand and to the temperature controller (8-pin connector at the back panel).
- » Make sure that the mains switch at the back panel of the controller is switched off and connect the controller to the power supply using the power cord.
- » Switch on the controller. The message „Sbr“ will appear on the control panel (see picture below). This means that a „sensor break“ is registered since no measuring cell is connected to the cell stand.



- » Put a small amount of heat sink compound on the surface of the peltier element and on the bottom of the measuring cell loaded with your sample.



ADVICE: Please do not use too much heat sink compound since it might enter the USB plug of the measuring cell and could negatively influence temperature control as well as the results of your measurement.

- » Slide the measuring cell carefully along the guide onto the peltier element until the USB connector engages. Now, the current temperature of the measuring cell should be depicted on the control panel.



ADVICE: Please do not modify your measuring cell after having positioned it on top of the peltier element by e.g. screwing the cap since lateral forces might damage the peltier element by overburdening the upper ceramic stage.

- » In case you want to control the temperature from your PC, connect the PC with the controller using the 9-pin D sub cable. If you do not have any native serial port at your PC, you can use an USB to serial converter which can also be purchased from rhd instruments.

rhd adapter boxes

All connections to measuring cells used with the Microcell HC setup come with cables offering BNC connectors (female) for establishing the connections to a measuring device. Also the cell stand has a BNC connector (female) at its back side for connecting the lower cell part. However, many manufacturers of measuring devices offer other connector types, e.g. banana plugs. Therefore, a suitable adapter is required. rhd instruments can provide you with these items which are well-adapted for your situation. In case you want to use measuring devices purchased from METROHM Autolab B.V., from Bio-Logic SAS or from Zahner-Elektrik GmbH & Co. KG, we already have boxes with a suitable design on stock. In the following, the adapter box designed for usage with devices manufactured by Autolab is presented.

Best choice for Autolab devices: adapter box type „PS“

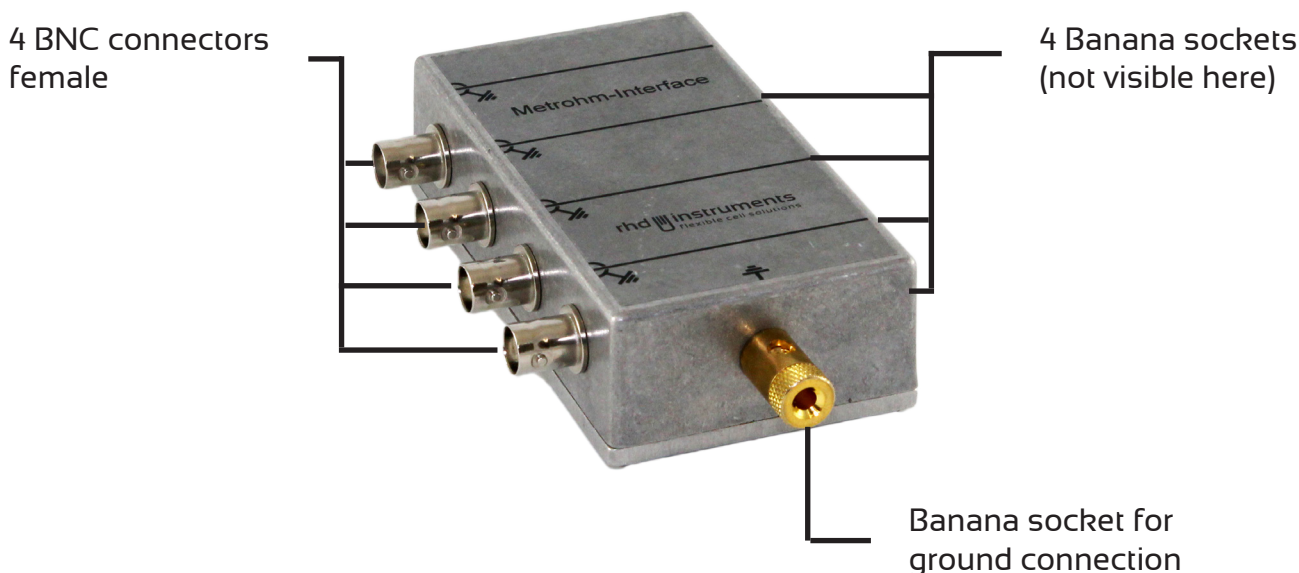

The box arrives at your site with 3 x 30 cm BNC cables with 2 BNC connectors (male) per cable. The cables should be used to connect the BNC connectors (female) of the cell cable (4 x BNC to 4-pole LEMO) and the BNC connector (female) of the cell stand to the adapter box.

In principle, two different configurations are commonly used for performing electrochemical experiments, depending on the method applied. These are either a 2-electrode or a 3-electrode configuration. For Autolab devices, schematic sketches showing both options are depicted on the following page.



ADVICE: The exact configuration of the connection of the adapter box to your measuring cell depends on the method applied as well as on the chosen measuring cell. The pictures only show an exemplary configuration which can be used e.g. in cases when a TSC 1600 closed combined with a cap offering 4 separate platinum electrodes is used.

2-electrode configuration

To Microcell HC setup equipped with measuring cell

To Autolab measuring device, e.g. PG-Stat204

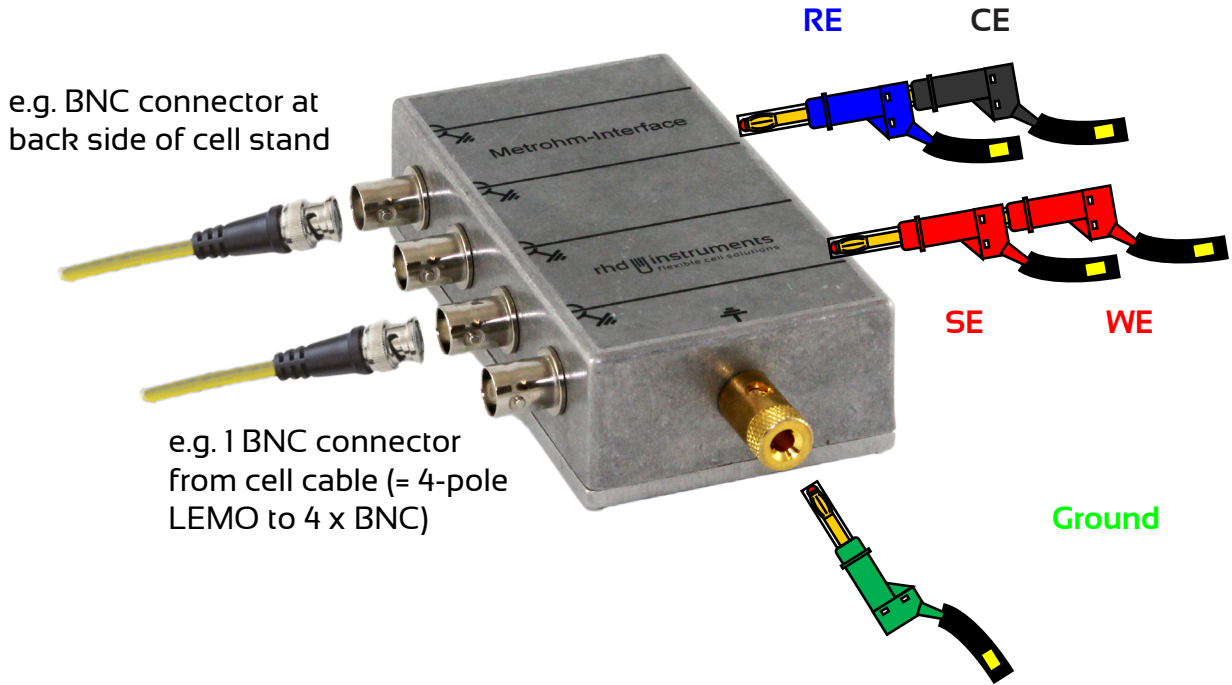

3-electrode configuration

To Microcell HC setup equipped with measuring cell

To Autolab measuring device, e.g. PG-Stat204

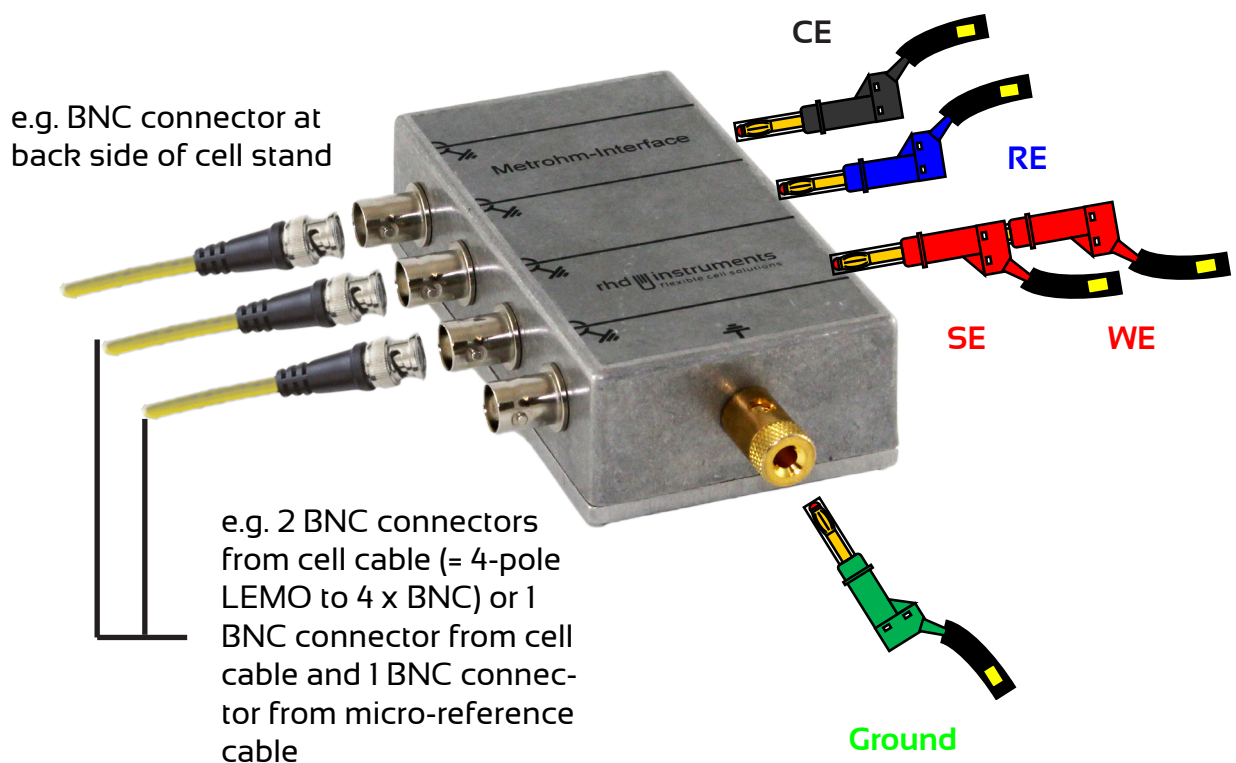

Settlement

Explicitly left out from warranty are parts that are subject to premature wear and tear due to use or other natural wear and tear (such as, for example, the micro-reference electrode and the respective fittings, the regeneration electrolyte for the micro-reference electrode, the mount for the lithium reference electrode, electrodes in general, and all sealing materials). These components are regarded as consumables.

The costs for sending repaired or exchanged goods to the customer will be paid for by rhd instruments.

rhd instruments has to be notified of apparent defects and damages that already occurred during production or delivery within 14 days after receiving the delivery. If notification of apparent defects and damages does not occur within this period of time, the goods shall be deemed to have been accepted; as a result, the order will be assumed to be completed and approved.

Please note: Only workshops authorized by rhd instruments are allowed to perform repairs on the devices. If the mechanical or electronic components of the products are altered by the customers themselves or by unauthorized workshops, a claim for warranty against rhd instruments is also forfeited.

In case of a claim or sending back goods for repairs to be performed, please ask for the decontamination form beforehand, in which you certify that the product has been decontaminated. In general, rhd instruments must be contacted via e-mail or phone prior to any shipping of damaged goods.

Contact and Technical Support

For any questions with regard to our products, orders, or request for repairs please contact rhd instruments:

info@rhd-instruments.com

Phone: +49 6151 8707187

Fax: +49 6151 8707189

Web: <http://www.rhd-instruments.com>

rhd instruments GmbH & Co. KG

Otto-Hesse-Straße 19

64293 Darmstadt

Germany

Sitz der Gesellschaft: Darmstadt

Amtsgericht Darmstadt HRA 85824

WEEE-Reg.-Nr. DE 54715752

Haftende Gesellschafterin: rhd instruments Verwaltungs GmbH

(Sitz: Darmstadt, Amtsgericht Darmstadt HRB 96374)

Geschäftsführer: Dr. Benedikt Huber und Dr. Marcel Drüschler

EU-Konformitätserklärung EU Declaration of conformity



Messsystem „Microcell HC“
Measuring Set-up „Microcell HC“

Wir, die rhd instruments GmbH & Co. KG,

We, rhd instruments GmbH & Co. KG,

rhd instruments GmbH & Co. KG

Otto-Hesse-Straße 19

64293 Darmstadt

Germany

erklären, dass das Messsystem Microcell HC in Konzeption und Bauart sowie in der von uns in Verkehr gebrachten Ausführung den grundlegenden Anforderungen der zutreffenden, aufgeführten EU-Richtlinien entspricht. Bei einer mit uns nicht abgestimmten Änderung an dem Gerät verliert diese Erklärung ihre Gültigkeit.

hereby declare, that the measuring set-up Microcell HC is in compliance with the basic requirements of all applicable EU-directives stated below with regard to design, type of model sold and manufactured by us. This certificate will be invalid if the product is modified without the prior written consent and agreement of the manufacturer.

Niederspannungsrichtlinie 2014/35/EU / Low-Voltage Directive 2014/35/EU

Angewandte (harmonisierte) Normen / (Harmonized) Standards applied:

DIN EN 61010-1: Sicherheitsbestimmungen für elektrische Mess-, Steuer-, Regel- und Laborgeräte Teil 1: Allgemeine Anforderungen (IEC 61010-1:2010 + Cor.:2011)

Darmstadt, 01. Februar 2017

Dr. Benedikt Huber

Dr. Marcel Druschler

(Geschäftsführer rhd instruments Verwaltungs GmbH)